

BJC-2000

SERVICE MANUAL

REVISION 0

Canon

OCT. 1998

QY8-1362-000

1098 SC 0.40-0

BJC-2000

SERVICE MANUAL

Canon

Application

This manual has been issued by Canon Inc. for qualified persons to learn technical theory, installation, maintenance, and repair of products. This manual covers all localities where the products are sold. For this reason, there may be information in this manual that does not apply to your locality.

Corrections

This manual could include technical inaccuracies or typographical errors due to improvements or changes in the products. When changes occur in applicable products or in the content of this manual, Canon will release technical information as the need arises. In the event of major changes in the contents of this manual over a long or short period, Canon will issue a new editions of this manual.

The following paragraph does not apply to any countries where such provisions are inconsistent with local law.

Trademarks

The product names and company names described in this manual are the registered trademarks of the individual companies.

Copyright

This manual is copyrighted with all rights reserved. Under the copyright laws, this manual may not be copied, reproduced or translated into another language, in whole or in part, without the written consent of Canon Inc., except in the case of internal business use.

Copyright © 1998 by Canon Inc.

CANON INC.

BJ Products Technical Support Dept

16-1, Shimonoge 3-chome, Takatsu-ku, Kawasaki-shi, Kanagawa 213, Japan

This manual was produced on an Apple Macintosh™ Power Mac 8500/180 personal computer and Apple LaserWriter™ 16/600PS-J laser beam printer; final pages were printed on Varityper™ 5300 with 4000-J RIP. All graphics were produced with MACROMEDIA® FREEHAND® 7.0J. All documents and all page layouts were created with QuarkXPress™ 3.3J.

I. ABOUT THIS MANUAL

This manual is divided into four sections, and contains information required for servicing the unit.

Part 1: Safety and Precautions

This section tells you how to service the unit safely. It is very important, so please read it.

Part 2: Product Specifications

This section outlines and specification.

Part 3: Operating Instructions

This section explains how to operate the unit properly. Information required about installation and service made.

Part 4: Technical Reference

This section outlines the way the unit operates so you can understand it technically.

Part 5: Maintenance

This section explains how to maintain the unit. Descriptions of assembly/disassembly, adjustment for assembly, troubleshooting procedures, and wiring/circuit diagrams are given.



Procedures for assembly/disassembly are not given in this manual.
See the illustrations in the separate Parts Catalog.

II. TABLE OF CONTENTS

	<i>Part 1: Safety and Precautions</i>
1 - 1	1. SAFETY PRECAUTIONS
1 - 1	1.1 Moving Parts
1 - 2	1.2 Ink Stains
1 - 2	1.2.1 Ink path
1 - 3	1.2.2 Ink mist
1 - 4	1.3 BJ Cartridge Heat-Up
1 - 5	2. MACHINE PRECAUTIONS
1 - 5	2.1 Precautions for Handling BJ Cartridges
1 - 5	2.1.1 Turning the printer ON/OFF
1 - 5	2.1.2 When the printer is not in use
1 - 5	2.1.3 Transportation precautions
1 - 5	2.1.4 Ink electroconductivity
1 - 6	2.2 Printer Precautions
1 - 6	2.2.1 Spur deformation prevention
1 - 6	2.2.2 Static electricity damage prevention
1 - 7	3. PRECAUTIONS FOR SERVICE
1 - 7	3.1 EEPROM Data Precautions
1 - 8	3.2 Static Electricity Precautions
1 - 8	3.3 Disassembly and Reassembly Precautions
1 - 8	3.4 Self-Diagnosis

Part 2: Product Specifications

2 - 1	1. PRODUCT OUTLINE
2 - 1	1.1 Product Outline
2 - 2	1.2 Features
2 - 3	1.3 BJ Cartridge
2 - 3	1.3.1 Color BJ cartridge (Multi-Drop)
2 - 3	1.3.2 Black BJ cartridge
2 - 3	1.3.3 Photo BJ cartridge (Multi-Drop)
2 - 4	1.4 BJ Cartridge Container
2 - 4	1.5 Consumables
2 - 4	1.5.1 BJ cartridges (Color, Black, Photo)
2 - 4	1.5.2 Ink cartridge (Color BJ cartridge)
2 - 5	1.6 Option
2 - 5	1.6.1 Color image scanner cartridge
2 - 5	1.6.2 Scanning holder
2 - 5	1.6.3 White calibration sheet
2 - 6	2. SPECIFICATIONS
2 - 6	2.1 Printer Specifications
2 - 9	2.2 Scanner Cartridge Specifications (Option)
2 - 10	2.3 Paper Specifications
2 - 10	2.3.1 Paper size
2 - 10	2.3.2 Paper type (Recommended)
2 - 10	2.3.3 Paper setting
2 - 11	2.3.4 Printable area
2 - 12	2.4 Interface Specifications

Part 3: Operating Instructions

3 - 1	1. PRINTER SETUP
3 - 1	1.1 Equipment Check
3 - 2	1.2 Printer Dimensions
3 - 3	1.3 Setup Procedure

Page	
3 - 3	1.3.1 Connecting the interface cable
3 - 3	1.3.2 Turning on the printer
3 - 4	1.3.3 Installing the cartridge
3 - 6	1.3.4 Scanner cartridge precautions
3 - 7	1.3.5 Replacing the ink cartridge
3 - 9	1.3.6 BJ cartridge container
3 -10	1.4 Turning the Printer On/Off
3 -10	1.4.1 Turning the printer on
3 -10	1.4.2 Turning the printer off
3 -11	1.5 Paper Settings
3 -11	1.6 Banner Printing
3 -12	1.7 Scanning Precautions
3 -13	1.8 Name of the Parts and Their Functions
3 -15	2. PRINTER SERVICING FUNCTIONS
3 -15	2.1 Error Indications
3 -17	2.2 Cleaning the BJ Cartridge
3 -17	2.3 Self-Test Printout
3 -17	2.3.1 Nozzle check pattern
3 -18	2.3.2 Service test print
3 -19	2.4 EEPROM Reset
3 -19	2.4.1 EEPROM Reset
3 -19	2.4.2 Printing the EEPROM data

Part 4: Technical Reference

4 - 1	1. OVERVIEW
4 - 1	1.1 Printer Diagram
4 - 2	1.2 Print Signal Flow
4 - 3	1.3 Print Drive
4 - 3	1.3.1 Printing drive control
4 - 5	2. FIRMWARE
4 - 5	2.1 720 dpi Printing Feature
4 - 5	2.1.1 Canon extended mode
4 - 6	2.2 Printing Modes
4 - 6	2.2.1 Printing mode
4 - 6	2.2.2 Photo print mode
4 - 6	2.2.3 Multi-drop print mode
4 - 8	2.3 Optimum Printing Direction Control
4 - 8	2.4 Ink Smear Control
4 - 8	2.5 Head Overheating Protection Control
4 - 9	3. PRINTER MECHANICAL SYSTEM
4 - 9	3.1 Overview
4 - 9	3.1.1 Mechanical components
4 -10	3.2 BJ Cartridge
4 -10	3.2.1 Black BJ cartridge structure
4 -11	3.2.2 Color BJ cartridge structure
4 -12	3.2.3 Photo BJ cartridge structure
4 -13	3.2.4 Bubble head unit structure
4 -17	3.3 Purge Unit
4 -17	3.3.1 Purge unit functions
4 -18	3.3.2 Purge unit structure
4 -19	3.4 Carriage
4 -19	3.4.1 Carriage functions
4 -20	3.4.2 Carriage structure
4 -22	3.5 Paper Feed

Page	
4 -22	3.5.1 Outline of the paper feed
4 -23	3.5.2 Structure of the sheet feeder
4 -24	4. PRINTER ELECTRICAL SYSTEM
4 -24	4.1 Overview
4 -25	4.2 Logic Section
4 -25	4.2.1 Logic section block diagram
4 -26	4.2.2 Logic section components
4 -28	5. SENSOR FUNCTIONS
4 -28	5.1 Pick-Up Roller Sensor
4 -28	5.2 Paper End Sensor
4 -28	5.3 Home Position Sensor (Purge Sensor)
4 -28	5.4 Temperature Sensor
4 -29	5.5 Head Temperature Sensor
4 -29	5.6 Waste Ink Amount Detection
4 -30	6. SCANNER CARTRIDGE
4 -30	6.1 Scanner Cartridge Overview
4 -30	6.1.1 Block diagram
4 -31	6.2 Scanner Cartridge Structure
4 -33	6.3 Signal Contacts
4 -33	6.4 Scan Mode
4 -33	6.5 Calibration

Part 5: Maintenance

5 - 1	1. MAINTENANCE
5 - 1	1.1 Parts for Regular Replacement
5 - 1	1.2 Consumables
5 - 1	1.3 Periodic Maintenance
5 - 2	2. SERVICING TOOLS
5 - 2	2.1 List of Tools
5 - 3	3. GREASE APPLICATION
5 - 4	4. DISASSEMBLY AND REASSEMBLY
5 - 4	4.1 Disassembly and Reassembly
5 - 4	4.2 Disassembly and Reassembly Cautions
5 - 5	4.3 Logic Board and Bottom Cover Replacement Cautions
5 - 5	4.3.1 Logic board replacement cautions
5 - 5	4.3.2 Cautions after replacing the bottom cover
5 - 6	5. TROUBLESHOOTING
5 - 6	5.1 Troubleshooting
5 - 6	5.1.1 Overview
5 - 6	5.1.2 Troubleshooting cautions
5 - 8	5.2 Error Condition Diagnosis
5 - 8	5.2.1 Initial self check
5 -10	5.2.2 Error recovery
5 -23	6. LOCATION & SIGNAL ASSIGNMENT
5 -23	6.1 Logic Board
5 -25	6.2 Carriage Ribbon Cable
5 -26	6.3 BJ Cartridge & Scanner Cartridge
5 -28	7. CIRCUIT DIAGRAMS
5 -28	7.1 Parts Layout
5 -28	7.1.1 Logic board

III. ILLUSTRATION INDEX

Page		
1 - 1	Figure 1- 1	Moving Parts of the Printer
1 - 2	Figure 1- 2	Ink Path
1 - 3	Figure 1- 3	Ink Path of the BJ Cartridge
1 - 3	Figure 1- 4	Ink Mist
1 - 4	Figure 1- 5	BJ Cartridge Aluminum Plate
1 - 6	Figure 1- 6	Spurs and Spur Cleaners
1 - 6	Figure 1- 7	Carriage Ribbon Cable's Electrical Contacts
1 - 8	Figure 1- 8	Electrical System of Printer
1 - 8	Figure 1- 9	How to Release Plastic Hooks
2 - 1	Figure 2- 1	Printer Exterior
2 - 3	Figure 2- 2	Color BJ Cartridges
2 - 4	Figure 2- 3	BJ Cartridge Container
2 - 4	Figure 2- 4	Ink Cartridges
2 - 5	Figure 2- 5	Scanner Cartridge
2 - 5	Figure 2- 6	Scanning Holder
2 -11	Figure 2- 7	Printing Area
2 -11	Figure 2- 8	Printing Area (Envelope)
2 -11	Figure 2- 9	Printing Area (Banner Paper)
2 -18	Figure 2-10	Timing Chart (Compatible Mode)
2 -19	Figure 2-11	Timing Chart (Nibble Mode)
2 -20	Figure 2-12	Timing Chart (ECP Mode)
3 - 1	Figure 3- 1	Packaging
3 - 2	Figure 3- 2	Printer Dimension
3 - 3	Figure 3- 3	Connecting the Interface Cable
3 - 4	Figure 3- 4	Removing the BJ Cartridge Protectors
3 - 4	Figure 3- 5	BJ Cartridge Handling Precautions
3 - 5	Figure 3- 6	Cartridge Installation
3 - 6	Figure 3- 7	Scanner Cartridge
3 - 7	Figure 3- 8	Removing the Ink Cartridge
3 - 8	Figure 3- 9	Removing the Ink Cartridge Cap
3 - 8	Figure 3-10	Ink Cartridge Protection
3 - 9	Figure 3-11	BJ Cartridge Container
3 -10	Figure 3-12	Never unplug the power cord less than one minute after completing an operation
3 -11	Figure 3-13	Banner Printing
3 -12	Figure 3-14	Scanning Holder
3 -13	Figure 3-15	Name of the Parts and Their Functions
3 -14	Figure 3-16	Name of the Parts and Their Functions
3 -14	Figure 3-17	Paper Thickness Lever
3 -17	Figure 3-18	Nozzle Check Pattern
3 -18	Figure 3-19	Service Test Print
4 - 1	Figure 4- 1	Printer Diagram
4 - 2	Figure 4- 2	Printing Signal Flow
4 - 3	Figure 4- 3	Printing Sequence (Black BJ Cartridge/HQ Mode)
4 - 4	Figure 4- 4	Printing Signals
4 - 5	Figure 4- 5	720 dpi Printing Feature
4 - 9	Figure 4- 6	Printer's Mechanical Configuration
4 -10	Figure 4- 7	Black BJ Cartridge Structure
4 -11	Figure 4- 8	Color BJ Cartridge Structure
4 -12	Figure 4- 9	Photo BJ Cartridge Structure
4 -13	Figure 4-10	Bubble Jet Nozzles (Partial View)
4 -14	Figure 4-11	Nozzle Arrangement

Page		
4 -14	Figure 4- 12	Black BJ Cartridge Block Diagram
4 -15	Figure 4- 13	Color (Multi-Drop)/Photo (Multi-Drop) BJ Cartridge Block Diagram
4 -18	Figure 4- 14	Purge Unit
4 -19	Figure 4- 15	Carriage
4 -20	Figure 4- 16	Paper Thickness Adjustment
4 -21	Figure 4- 17	Paper Feed Motor Drive Transmission
4 -22	Figure 4- 18	Paper Feed Mechanism
4 -23	Figure 4- 19	Paper Pick-Up Mechanism
4 -24	Figure 4- 20	Printer Electrical System
4 -25	Figure 4- 21	Logic Board Block Diagram
4 -25	Figure 4- 22	Printer Block Diagram
4 -28	Figure 4- 23	Sensors
4 -30	Figure 4- 24	Scanner Cartridge
4 -30	Figure 4- 25	Block Diagram
4 -31	Figure 4- 26	Scanner Cartridge
5 - 3	Figure 5- 1	Grease Application Points
5 - 5	Figure 5- 2	Bottom Cover
5 -23	Figure 5- 3	Logic Board
5 -25	Figure 5- 4	Carriage Ribbon Cable
5 -26	Figure 5- 5	Contact Pad
5 -28	Figure 5- 6	Logic Board (Top View)

IV. TABLE INDEX

Page		
3 -11	TABLE 3- 1	QUICK REFERENCE FOR SETTING
3 -15	TABLE 3- 2	ERROR INDICATIONS
3 -19	TABLE 3- 3	DEFAULT SETTING WHEN RESETTING THE EEPROM
4 - 7	TABLE 4- 1	PRINTING MODES AND HEATING METHODS
4 -16	TABLE 4- 2	HEAD INSTALLATION STATUS AND SIGNAL DETECTION
4 -17	TABLE 4- 3	INK CONSUMPTION DURING CLEANING (AS A STANDARD)
4 -29	TABLE 4- 4	LIST OF SENSOR FUNCTIONS
4 -33	TABLE 4- 5	LIST OF SCAN MODE

This page intentionally left blank



Part 1

SAFETY AND PRECAUTIONS

Page	
1 - 1	1. SAFETY PRECAUTIONS
1 - 1	1.1 Moving Parts
1 - 2	1.2 Ink Stains
1 - 4	1.3 BJ Cartridge Heat-Up
1 - 5	2. MACHINE PRECAUTIONS
1 - 5	2.1 Precautions for Handling BJ Cartridges
1 - 6	2.2 Printer Precautions
1 - 7	3. PRECAUTIONS FOR SERVICE
1 - 7	3.1 EEPROM Data Precautions
1 - 8	3.2 Static Electricity Precautions
1 - 8	3.3 Disassembly and Reassembly Precautions
1 - 8	3.4 Self-Diagnosis

1. SAFETY PRECAUTIONS

1.1 Moving Parts

The moving parts of the printer are shown below. They include the carriage belt, idler roller, carriage, slow down gear, paper feed roller, pressure roller, eject roller, spurs, and pick-up roller. The first three parts above are driven by the carriage motor while the latter are driven by the paper feed motor. Avoid getting hair, clothing, jewelry, etc., caught in these moving parts.

Also note that the spurs are made of metal and have sharp edges. Avoid touching the spurs with bare hands.

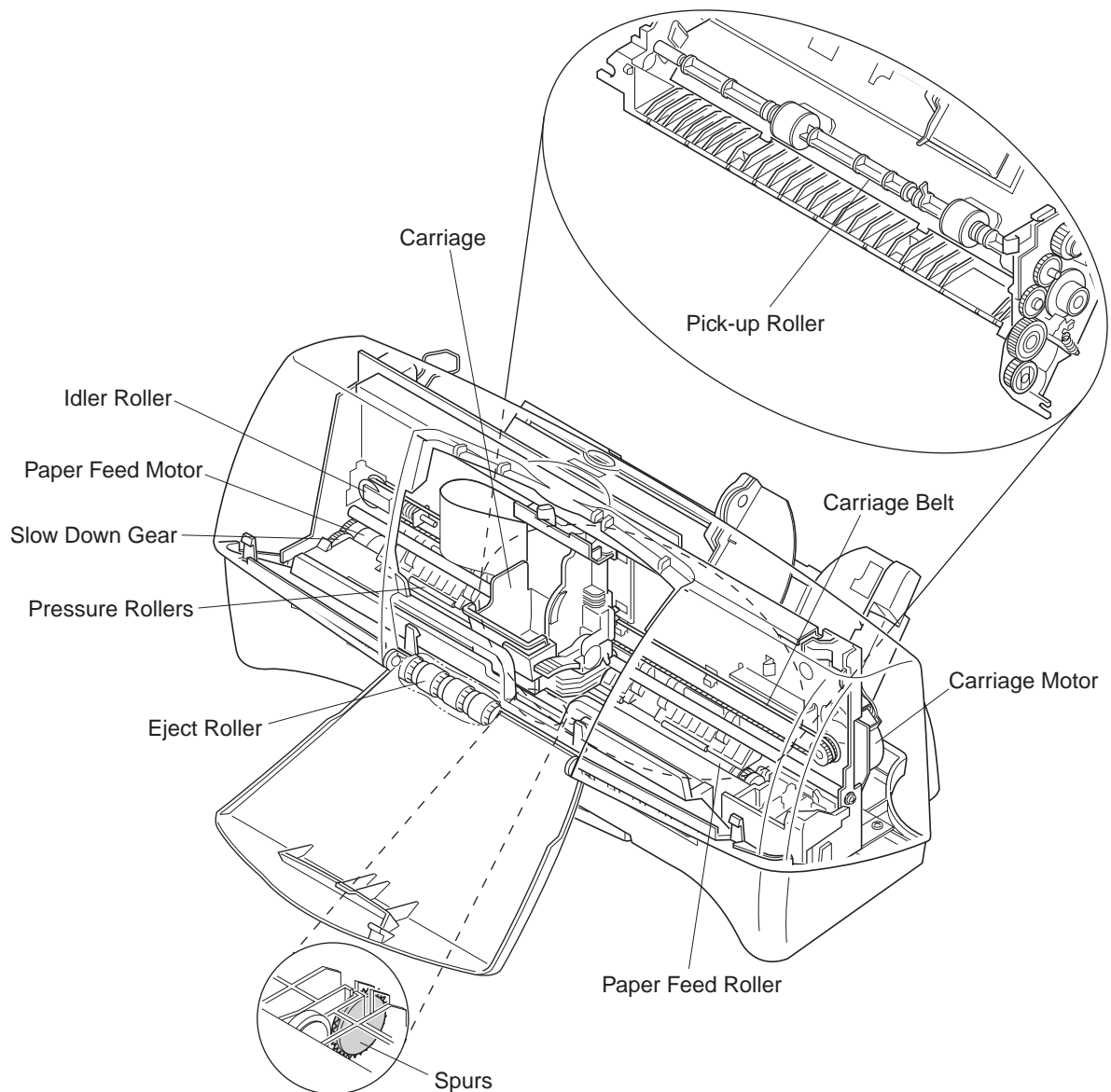

Figure 1-1 Moving Parts of the Printer

1.2 Ink Stains

1.2.1 Ink path

Do not touch the ink path while servicing as the ink can stain hands, work table, clothing, etc.

The ink path consists of the BJ cartridge nozzles, head cap, head wiper, maintenance jet receiving section, and waste ink absorber.

In the case of color BJ cartridges, the cartridge's ink outlets and joint pipes are also part of the ink path.

 Caution!
<p>Although the ink is non-toxic, it contains organic solvents. Isopropyl alcohol 67-63-0, glycerin 56-81-5, and ethyleneglycol 107-21-1 in black ink and isopropyl alcohol 67-63-0 in color inks. Do not get ink in your eyes and mouth. If any ink should get into your eyes, wash with plenty of water and consult a doctor. If a large amount of the ink is consumed, consult a doctor immediately.</p> <p>Give the doctor the information on the BJ cartridge label. Since the ink contains dyes, any ink stains on clothing, etc., are permanent.</p>

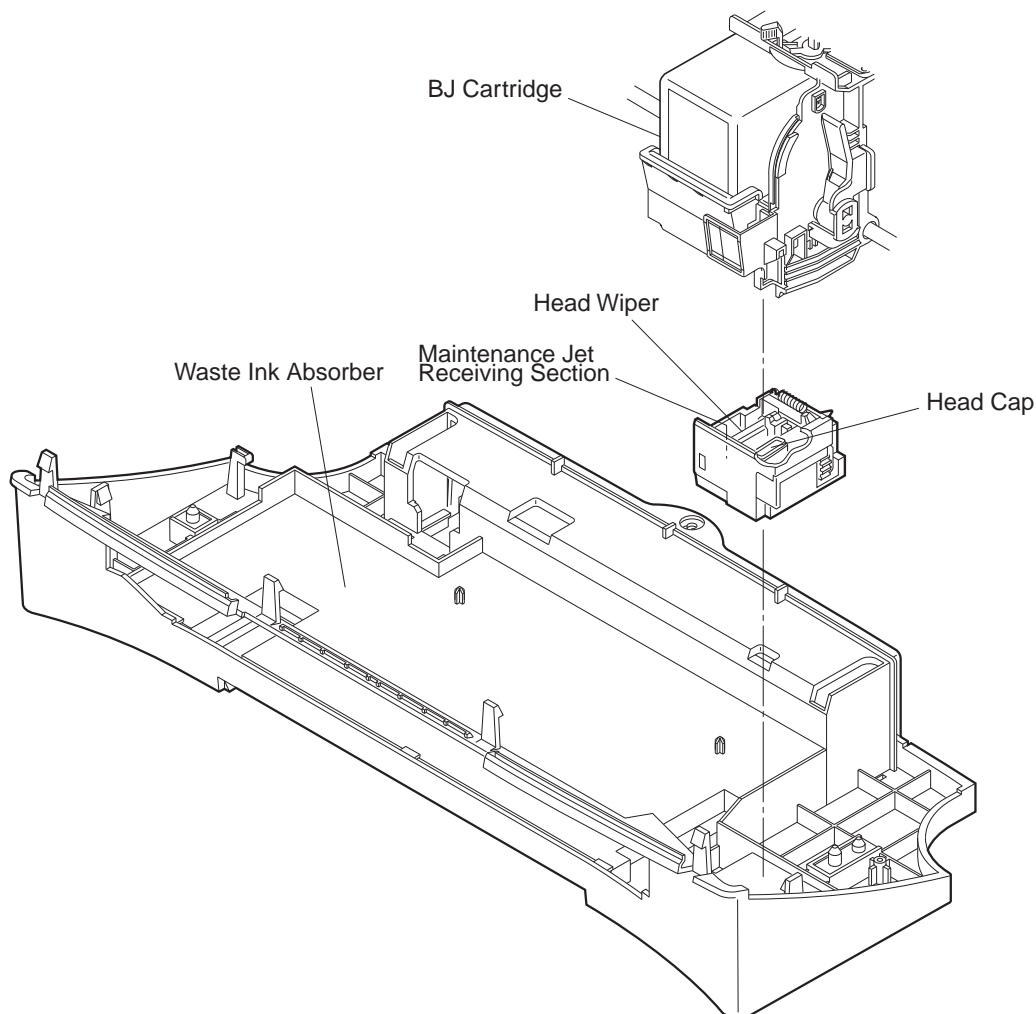

Figure 1-2 Ink Path

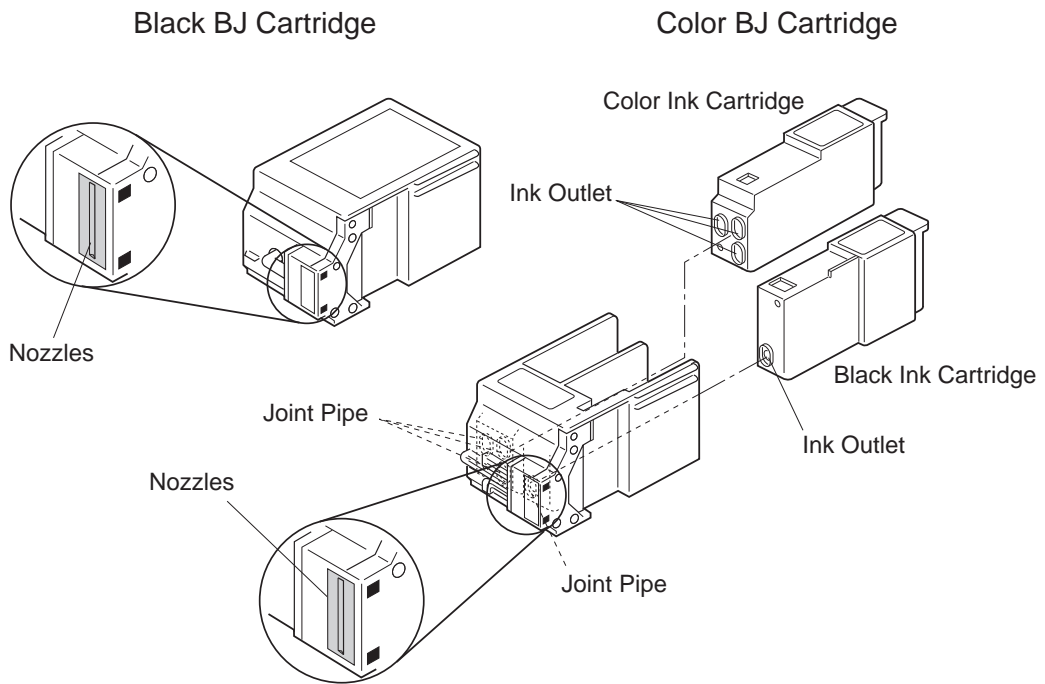

Figure 1-3 Ink Path of the BJ Cartridge

1.2.2 Ink mist

The BJ cartridge ejects ink onto the paper. During prolonged or heavy-duty use of the printer, small amounts of ink mist which splatter off paper during printing can contaminate the inside of the front cover and platen. Clean any contaminated parts with a soft moist cloth. Ink in such areas can contaminate the back of the paper and dirty hands and clothing while servicing.

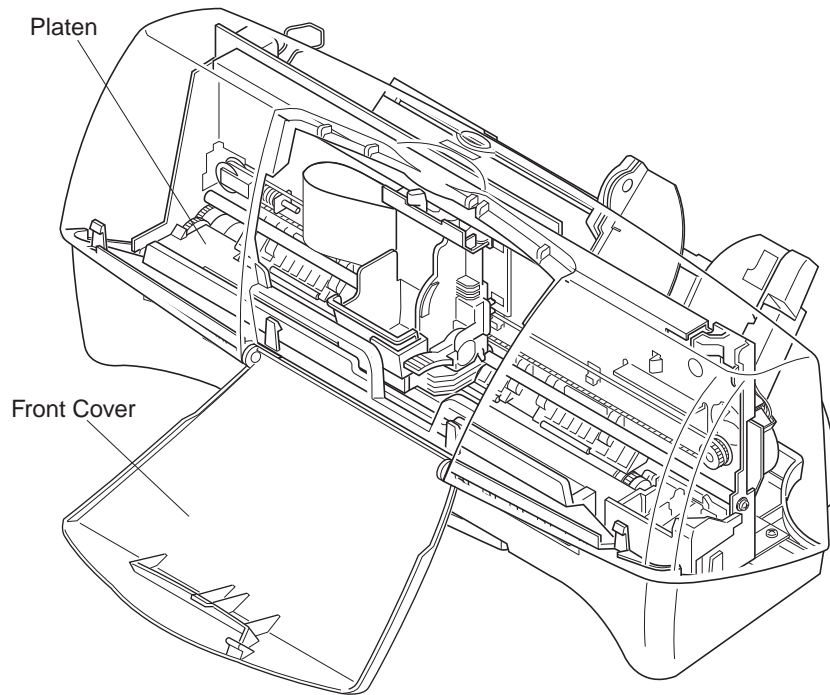

Figure 1-4 Ink Mist

1.3 BJ Cartridge Heat-Up

Do not touch the BJ cartridge's aluminum plate. The aluminum plate heats up during printing and becomes particularly hot during prolonged and continuous printing. It can overheat also if printing is continued even after the cartridge has run out of ink.

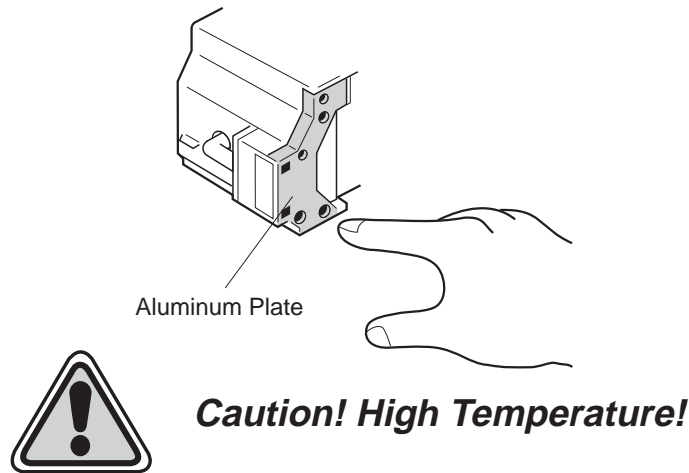

Figure 1-5 BJ Cartridge Aluminum Plate



The printer has a protective mechanism when the BJ cartridge heats up. The protective mechanism is activated when the head temperature (diode) sensor in the BJ cartridge senses a certain temperature.

Protection level 1:

This level prevents the user from touching the bubble jet head's hot aluminum plate when the bubble jet head is replaced. For this purpose, when the front cover is opened, the carriage will not move to the cartridge replacement position. Close the front cover, leave the printer inactive for a few minutes to allow it to cool, and then open the front cover again to perform the required operation.

Protection level 2:

If a high temperature is still detected, the carriage is returned to the home position for 3.5 seconds to bring down the temperature. After the resting period, printing will resume. This continues for over 20 seconds to lower the bubble jet head's temperature.

Protection level 3:

If the temperature continues to increase, a head temperature error occurs. This stops the printing operation.



When printing is stopped by a head temperature error or a head temperature sensor error, follow the troubleshooting procedures in *Part 5: 5.TROUBLESHOOTING* (page 5-6).

2. MACHINE PRECAUTIONS

2.1 Precautions for Handling BJ Cartridges

2.1.1 Turning the printer ON/OFF

The printer will automatically cap the cartridge heads one minute after printing operations are completed, to prevent the ink from leaking and drying out.

When unplugging the power cord, wait at least one minute after completing an operation such as printing, feeding paper, cleaning the print head, etc.

If the power cord is accidentally unplugged before one minute has passed, replug the AC adapter, and wait for more than one minute before unplugging the power cord.



If the nozzles are not capped, the ink may leak and dry out causing the nozzles to clog.

2.1.2 When the printer is not in use

BJ cartridges should be stored either installed in the printer or in the BJ cartridge container.



If the BJ cartridge is removed from the printer or BJ Cartridge Container, the ink may leak and dry out causing the nozzles to clog.

2.1.3 Transportation Precautions

When carrying or transporting the printer, keep the BJ cartridge stored in the BJ cartridge container.

This prevents the ink from leaking and drying out in the nozzles.

2.1.4 Ink electroconductivity

The ink in the BJ cartridge is electroconductive. If ink leaks into the printer's mechanical parts, use a damp paper towel, etc., to wipe clean. If it leaks into the printer's electrical components, use tissue paper, etc., to wipe clean completely. If ink gets into the IC chips on the PCB and it is difficult to clean, replace the PCB.



If ink has leaked inside the printer, do not plug in the power cord. It may damage the circuitry.

2.2 Printer Precautions

2.2.1 Spur deformation prevention

Do not deform the tips of the spurs.

The spurs come into contact with the paper after printing. As the actual contact surface is small, any ink adhering to the spurs is minute and wiped off by the spur cleaners. Therefore any ink on the spurs is not enough to contaminate the paper as it passes. However, if the spurs become deformed, their contact surface with the paper increases, causing more ink to adhere to each spur. Since the spur cleaner is unable to wipe off all the ink, a line of dotted ink may mask the printed paper.

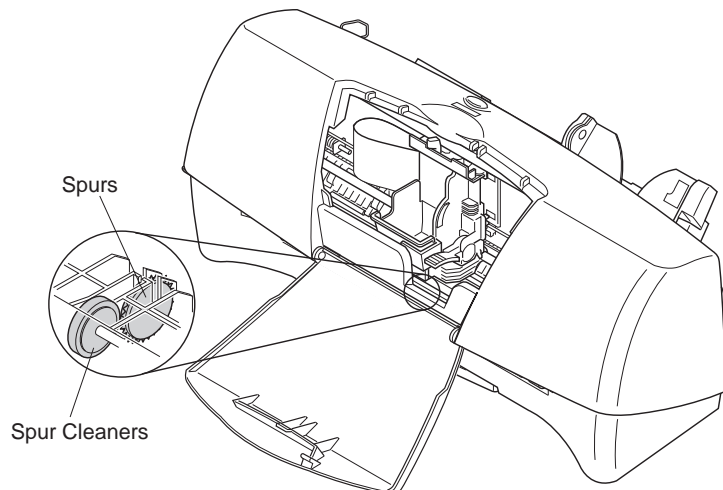

Figure 1-6 Spurs and Spur Cleaners

2.2.2 Static electricity damage prevention

The static charge that accumulates from clothing, etc., can damage electrical components. Therefore, never touch the electrical contacts of the carriage ribbon cable and BJ cartridge.



Electrostatic Discharge!

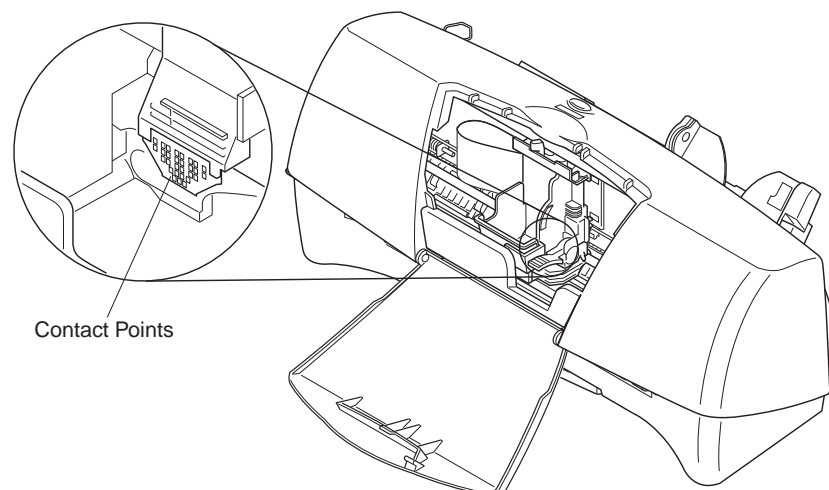

Figure 1-7 Carriage Ribbon Cable's Electrical Contacts

3. PRECAUTIONS FOR SERVICE

3.1 EEPROM Data Precautions

The printer keeps track of various settings, the total waste ink amount, and the total sheets printed with the black, color and photo BJ cartridges. This data is stored in the EEPROM on the logic board. Note the following precautions during servicing:

1) Before servicing

Check the EEPROM data with a test print. The total sheets printed can give you an idea of how much the printer has been used.

2) During logic board (EEPROM) replacement

Always visually check the waste ink amount absorbed by the waste ink absorbers and replace them when necessary as explained in *Part 5: 4.3 Logic Board and Bottom Cover Replacement Cautions (page 5-5)*.

If the waste ink absorbers are not visually checked regularly, they may reach or exceed their full capacity before “waste ink full” is detected. The waste ink may therefore start leaking.

The memory data for the replacement logic board (EEPROM) is not defined.

Therefore, after replacing the logic board (and EEPROM), reset the total waste ink amount to zero by clearing the data.

3) After waste ink absorber replacement

After replacing the waste ink absorbers, reset the total waste ink amount to zero by clearing the EEPROM data.



After the EEPROM is reset, the data it contained cannot be printed out with a test printout. If you want to check the stored data, be sure to execute test printout before resetting the EEPROM.

When the stored data is reset, the various settings, the total count of printed sheets, and the total waste ink amount will all be reset. The total sheets printed and waste ink amount cannot be input using the operation panel.



Immediately after the printer is turned on, it keeps track of the estimated waste ink amount based on the usage conditions. To prevent ink leakage when the waste ink amount exceeds the waste ink absorption capacity, the printer stops printing and indicates an error when the waste ink absorption capacity is close to being full.

For details on checking the EEPROM data with a test printout and for clearing the data, see *Part 3: 2.4 EEPROM Reset (page 3-19)*.

If the printer stops operating in the case of a waste ink full error, follow the countermeasures described in *Part 5: 5.1 Troubleshooting (page 5-6)*.

3.2 Static Electricity Precautions

The static charge accumulated from clothing, etc., can damage electrical components. To discharge any built-up static electricity, touch a metallic object that is grounded. Be sure to do this before disassembling the printer for servicing. Before discharging the static charge, do not touch the electrical contacts on the logic board and on the carriage ribbon cable (see *Figure 1-7*) while the carriage ribbon cable is connected to the logic board.

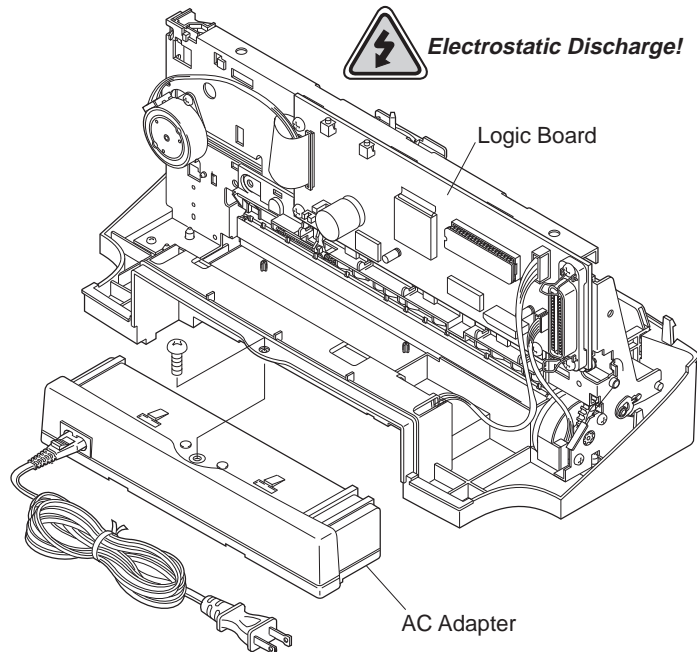

Figure 1-8 Electrical System of Printer

3.3 Disassembly and Reassembly Precautions

The printer is comprised of a large number of plastic parts. When disassembling the printer, take care not to break or bend plastic hooks.



Some plastic parts contain glass fibers for extra rigidity and precision, but since their viscosity is low, plastic hooks can break easily when excessive force is used. Use a precision screwdriver, and do not pull plastic hooks with excessive force while unhooking them.

3.4 Self-Diagnosis

The printer has a self-diagnosis feature to detect hardware defects. The results of the self-diagnosis is indicated on the host computer's screen as an error. (The host computer should be set in ECP or nibble mode, and uses the BJ status monitor under Windows95/98.) For details, see *Part 3: 2.1 Error Indications (page 3-15)*.

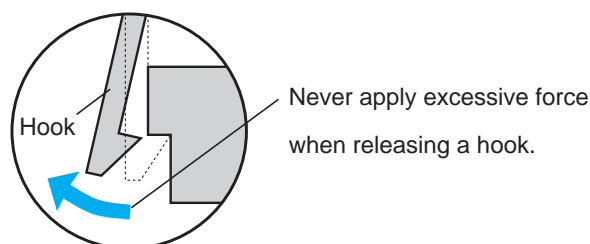

Figure 1-9 How to Release Plastic Hooks



Part 2

PRODUCT SPECIFICATIONS

Page	
2 - 1	1. PRODUCT OUTLINE
2 - 1	1.1 Product Outline
2 - 2	1.2 Features
2 - 3	1.3 BJ Cartridge
2 - 4	1.4 BJ Cartridge Container
2 - 4	1.5 Consumables
2 - 5	1.6 Option
2 - 6	2. SPECIFICATIONS
2 - 6	2.1 Printer Specifications
2 - 9	2.2 Scanner Cartridge Specifications (Option)
2 -10	2.3 Paper Specifications
2 -12	2.4 Interface Specifications

1. PRODUCT OUTLINE

1.1 Product Outline

This printer is a value-added, Windows-based, full-color bubble jet desktop printer that has realized high-quality image printing through the implementation of the PhotoRealism concept.

The printer has achieved high-quality printing by using color BJ cartridges/photo BJ cartridges in which "drop modulation technology" has been adopted. It also features banner printing capability to expand its printing environment. If an optional scanner cartridge is installed in the carriage, the printer can also be used as a compact color scanner.

This is a high-performance, personal color printer, which has achieved small size and light weight as well.

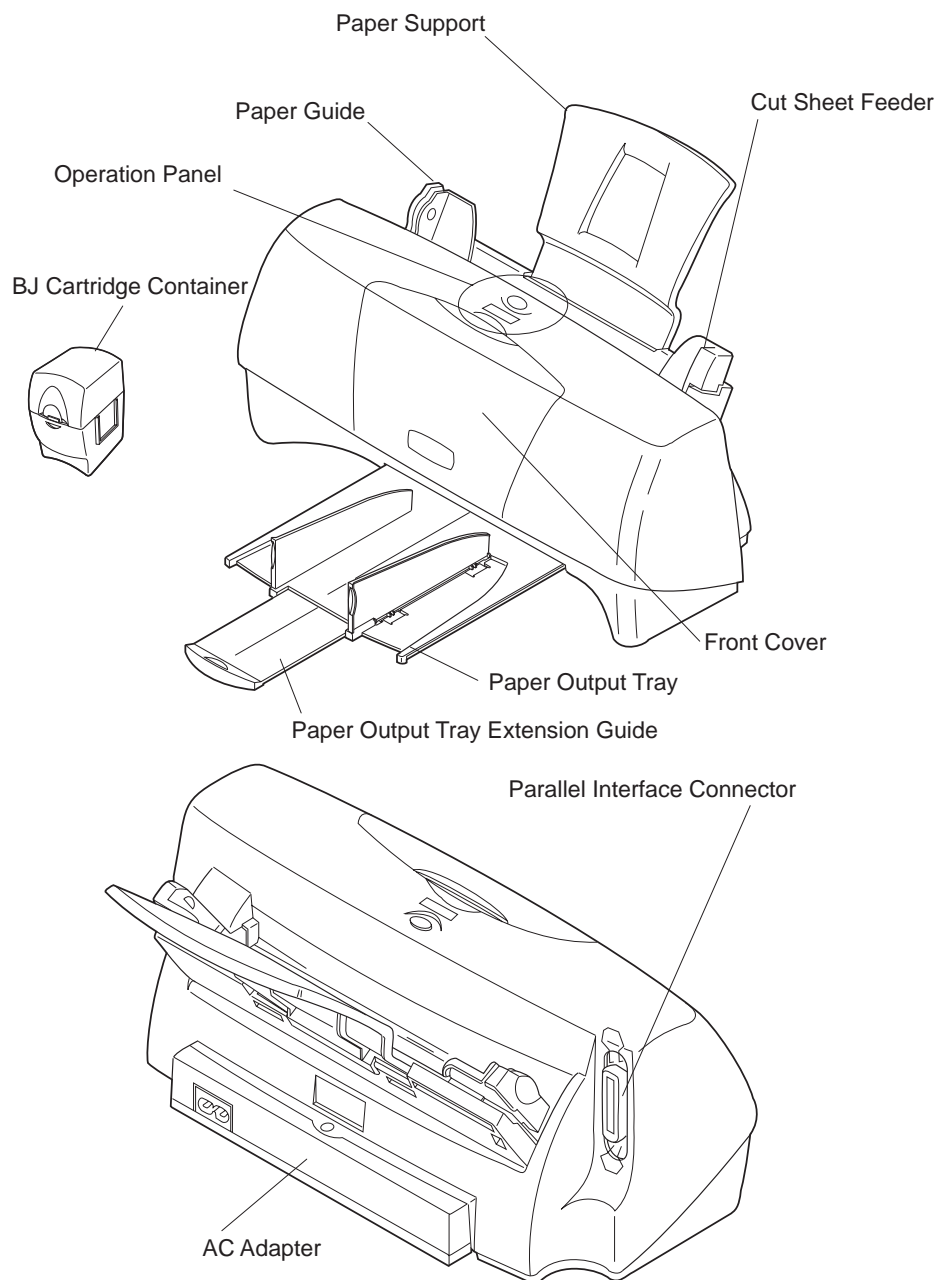

Figure 2-1 Printer Exterior

1.2 Features

1. Compact (desk-top size)
External dimensions: 370 mm W × 191 mm D × 161 mm H
Weight: Approx. 2.4 kg (5.3 lbs) (excluding BJ cartridge and option)
2. Only *RESET* button on the operation panel (No LED and buzzer)
Errors will be displayed on the host computer monitor. (The host computer should be set to ECP or Nibble mode and use the BJ status monitor on Windows95/98.)
3. New AC adapter
4. High quality printing of 720 × 360 dpi (in both monochrome and color)
5. Windows exclusive printer (used with the Canon original printer driver)
6. Drop modulation technology adopted Color & Photo BJ cartridges
7. Banner printing capability
8. New image processing technology "Image Optimizer" supported by the driver.
(Image optimizer: a function to reduce "jaggies" which occur when enlarging low resolution images.)
9. Improved printer driver color matching processing
10. Device ID and status response function compatible with Windows95 Plug & Play
(Responds to the device ID/status of nibble mode)
11. New leverless sheet feeder
12. New carriage (Two-positioned paper thickness lever. Three positions for the BJC-4400.)
13. High quality scanning using the optional color scanner cartridge (IS-22)
14. Cartridge container SB-21 packed with the printer (for BC-20/BC-21e/BC-22e Photo)

1.3 BJ Cartridge

1.3.1 Color BJ cartridge (Multi-Drop)

The disposable color BJ cartridge is comprised of a print head and two replaceable ink cartridges (black and color).

When the ink runs out, or more than 6 months elapse after the cartridge has been removed from its package, or if the print quality does not improve even after cleaning the head over five times, replace the ink cartridge. Furthermore, if the print quality does not improve following replacement of the ink cartridge and after cleaning is performed over 5 times, replace the BJ cartridge. Since the three color inks are integrated, when one ink color runs out, the entire color ink cartridge must be replaced.

Adopting drop modulation technology, small dots are printed in low density areas to minimize graininess and large dots are used for high density areas. Using this technology allows the printer to retain its printing speed and achieve high quality printing. On plain paper and transparencies, 360 dpi/720 dpi high-resolution printing is available.

1.3.2 Black BJ cartridge

The disposable BJ cartridge, is used for ultra-high-speed mono-chrome printing.

When the ink runs out, or more than 6 months elapse after the cartridge is removed from its package, or if the print quality does not improve even after cleaning the head over five times, replace the BJ cartridge. It allows printing at the same 360 dpi/720 dpi resolution as does the color BJ cartridge.

1.3.3 Photo BJ Cartridge (Multi-Drop)

The disposable photo BJ cartridge, used for printing color photographs, integrates a print head and four ink cartridges.

When the ink runs out, or more than 6 months elapse after the cartridge has been removed from its package, or if the print quality does not improve even after cleaning the head over five times, replace it with a new photo BJ cartridge. Since the four color inks are integrated, when one ink color runs out, the entire photo BJ cartridge must be replaced.

Adopting drop modulation technology, the photo BJ cartridge prints small dots in low density areas to minimize graininess and large dots in high density areas to retain its printing speed and achieve high quality printing.

Use high quality special paper for printing.

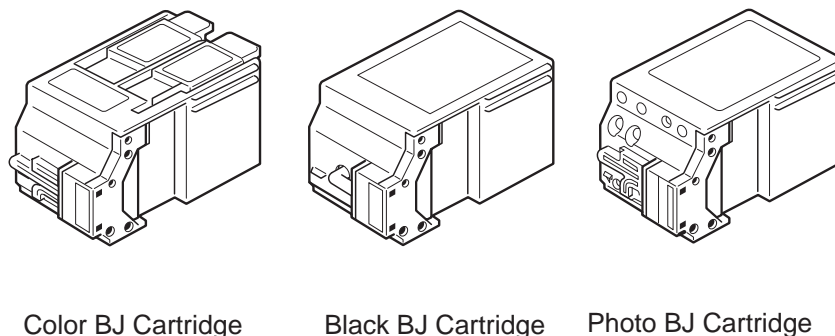

Figure 2-2 Color BJ Cartridges

1.4 BJ Cartridge Container

The cartridge container is for storing unused BJ cartridges black, color, and photo, to protect the head from damage. When storing a BJ cartridge in this container, be sure to close the cover. When storing a color BJ cartridge, do not remove the ink cartridges. The BJ cartridge containers can be linked together.

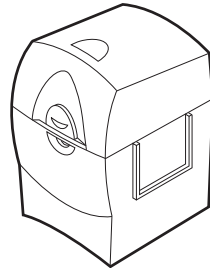

Figure 2-3 BJ Cartridge Container

1.5 Consumables

1.5.1 BJ cartridges (Color, Black, Photo)

Replacement BJ cartridges are identical to those included with the printer. Only the packaging is different.

1.5.2 Ink cartridge (Color BJ cartridge)

Replacement ink cartridges are the same as those installed in the color ink cartridge and black ink cartridge. Either cartridge can be used for half a year after the seal is opened.

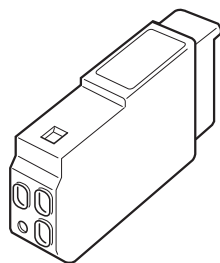

Color Ink Cartridge

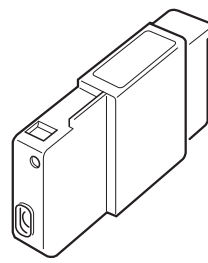

Black Ink Cartridge

Figure 2-4 Ink Cartridges

1.6 Option

1.6.1 Color image scanner cartridge

This printer can be used as a color scanner when a scanner cartridge is installed. To help stabilize the output of the LED which provides the scanner cartridge with its light source, when the scanner cartridge is just installed or when it is not engaged in reading operation, the printer makes the LED lit to pre-heat the scanner cartridge or keep it warmed up.

Also, in order to establish the "value of white color," which provides a reference for scanning images, the scanner needs to perform white calibration correction, using the white calibration sheet.

The calibration data is retained unless there is an ambient temperature change of $\pm 5^{\circ}\text{C}$ or the cartridge is removed and reinstalled.

Also for monochrome printing, edge emphasis processing is performed.

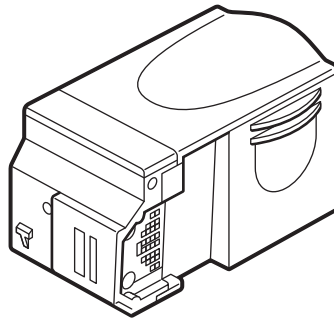

Figure 2-5 Scanner Cartridge

1.6.2 Scanning holder

The scanning holder protects the scanning document from the printer's sharp spurs that may damage the document during feeding. Small documents can also be scanned using the scanning holder. When the printer is used as a scanner, the scanning holder must be used at all times.

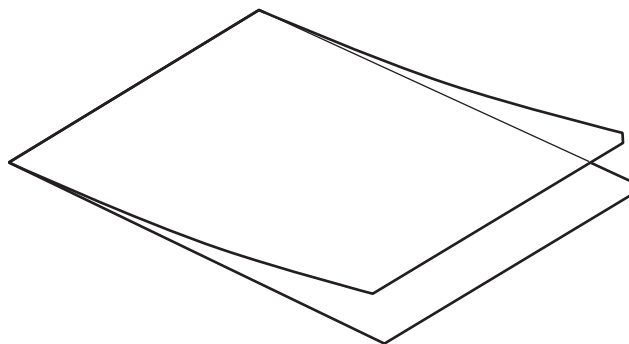

Figure 2-6 Scanning Holder

1.6.3 White calibration sheet

The printer uses a white calibration sheet to perform calibration. The white calibration sheet is set on the printer similar to the scanning holder. White calibration is performed in the initial setting of the printer driver. As the white calibration sheet is used to set the white standard value for scanning images, scanning input data may be affected if the sheet is dirty. Without damaging the sheet, use a soft moistened cloth to gently wipe off the dirt. If the sheet is still dirty, use a wet towel to wipe the sheet and dry it thoroughly before use.

2. SPECIFICATIONS

2.1 Printer Specifications

1. Type

Desktop serial color bubble jet printer

2. Paper feeding method

Auto sheet feed

3. Resolution

720 dpi × 360 dpi

4. Stacking capacity of sheet feeder

Plain paper	Max. 5 mm stack (approx. 50 pages with 75 g/m ² paper) LGL size: Max. 10 sheets
Envelopes	5 envelopes (Commercial number 10, DL-size)
Transparencies	Max. 20 sheets
Back print film	Max. 10 sheets
Glossy photo paper	Max. 1 sheet
Fabric	Max. 1 sheet
T-shirt transfer	Max. 1 sheet
Banner paper	Max. 1 sheet
Scanning document	Max. 1 page in carrier sheet (ASF)

5. Paper size

Letter (8.5" × 11")
 Legal (8.5" × 14")
 A4 (210 mm × 297 mm)
 Commercial number 10 envelopes (4.11" × 9.5")
 European DL-size envelopes (220 mm × 110 mm)

6. Paper type

Plain paper
 Envelopes (COM#10 or DL-size)
 Transparencies (Canon Transparencies CF-102)
 BPF (Canon Back Print Film BF-102)
 Glossy paper (Canon Glossy Photo Paper GP-201)
 Glossy film (Canon High Glossy Film HG-101)
 Color Plain Paper (Canon High Resolution Paper HR-101)
 Color Plain Paper (Canon Bubble Jet Paper LC-301)
 Fabric (Canon Fabric Sheet FS-101)
 Banner Paper (Canon Banner Paper BP-101)
 T-shirt transfers (Canon T-Shirt Transfers TR-201)

7. Printing weight

Automatic feed 64 to 105 g/m² (17 lbs to 28 lbs)

8. Printing speed (Throughput)

	Color printing (BC-21e)	Monochrome printing (BC-20)
HQ mode	1.5 ppm	3.8 ppm
HS mode	2.0 ppm	4.5 ppm
Measurement pattern	California Wine	PC-Magazine

9. Printing direction

Switching unidirectional
(Printing direction automatically changes according to the print data/print mode/installed cartridge type)

10. Print width

Max. 203.2 mm (8")

11. Line feed speed

150 ms/line (128/360" line feed)

12. Built in print control mode

Canon extended mode is supported when using the Canon original driver.

13. Receive buffer

31 KBytes

14. Interface

IEEE1284 compatible 8-bit parallel

15. BJ cartridges

BC-21e (Ink cartridge replaceable type color BJ cartridge)

Print head	136 nozzles in a vertical line
Ink color	Bk (64 nozzles) + Y, M, C (24 nozzles X 3)
No. of pages printable	Black: Approx. 160 pages (HQ mode, 1500 character pattern)/cartridge Color: Approx. 90 pages (HQ mode)/cartridge (7.5% duty per color pattern)
Weight	Approx. 85 g (3.0 oz) (including both ink cartridges)

BC-20 (Ink cartridge integrated type monochrome BJ cartridge)

Print head	128 nozzles in a vertical line
Ink color	Black
No. of pages printable	Approx. 700 pages (HQ mode)/cartridge
Weight	Approx. 85 g (3.0 oz)

BC-22e Photo (Ink cartridge integrated type monochrome BJ cartridge)

Print head	136 nozzles in a vertical line
Ink color	Bk (64 nozzles) + Y, M, C (24 nozzles X 3)
No. of pages printable (For reference)	Color: Approx. 50 pages (HQ mode)/cartridge (7.5% duty per color pattern)
Weight	Approx. 74 g (2.8 oz)

16. Detection functions

Paper out	Available
Presence of BJ cartridge	Available
Waste ink amount	Available
Paper width	None
Distinction of cartridge	Available
Ink out	None
Distinction of scanner	Available
BJ cartridge or scanner mismatch	Available

17. Noise

Sound pressure level* Approx. 45 dB (A)

*Conforming to sound pressure level ISO 9296

18. Environmental requirements

	Temperature	Humidity
During operation	5°C to 35°C (41°F to 95°F)	10% to 90% RH (no condensation)
Non operation	0°C to 35°C (32°F to 95°F)	5% to 95% RH (no condensation)

19. Power supply

	Input voltage/Frequency	Power consumption	Stand-by status
USA/Canada	AC120V 60 Hz	Approx. 30 W (Max.)	Approx. 2W
UK/Australia	AC 240V 50 Hz		
Europe	AC 230V 50 Hz		

20. External Dimensions

370 mm W × 191 mm D × 161 mm H

21. Weight

Approx. 2.4 kg (5.3 lbs) (excluding BJ cartridges and options)

2.2 Scanner Cartridge Specifications (Option)

1. Type

Cartridge replacement type color scanner

2. Image sensor

128 pixels in one line of CCD

3. Light source

LED (RGB), (alignment of red, green, blue, green, red ; five in total)

Using green LED for monochrome printing

4. Scanning method

Sequential RGB light source switching method

5. Scanning direction

Unidirectional

6. Picture signal output

Color 8-bit (256 gradation for each RGB color), Binary, Grayscale 8-bit

7. Resolution

Carriage scanning progression; 360/300/200/180/90 dpi

(300/200dpi are the resolution change from the software)

Paper feed progression; 360/180/90 dpi

8. Scanning speed (reference exclude paper pickup/ delivery and data transfer time)

Color, 8bit, ECP, A4:

4'31" (360 × 360 dpi), 2'56" (180 × 180 dpi), 2'31" (90 × 90 dpi)

Monochrome, 1bit, ECP, A4:

0'34" (360 × 360 dpi), 0'29" (180 × 180 dpi), 0'25" (90 × 90 dpi)

9. Interface

ECP/Nibble

10. Document feeding method

Place the document between the scanning holder and feed it through ASF.

11. Calibration

Scanning the white calibration sheet corrects the shading and white balance

12. Edge stress

Edge stress processing only applies to monochrome binary

13. Power consumption

Approx. 1.6 W

14. External dimensions

43.8 mm (W) × 41.8 mm (D) × 72.2 mm (H)

15. Weight

Approx. 60 g (2.1 oz)

2.3 Paper Specifications

2.3.1 Paper size

Letter (8.5" × 11")
 Legal (8.5" × 14")
 A5 (148 mm × 210 mm)
 A4 (210 mm × 297 mm)
 Commercial number 10 envelope (9.5" × 4.1")
 European DL-size (220 mm × 110 mm)

2.3.2 Paper type (Recommended)

Plain paper
 Bubble jet paper (Canon LC-301)
 Envelopes (Commercial number 10 or European DL)
 Transparencies (Canon transparency film CF-102)
 BPF (Canon back print film BF-102)
 Glossy photo paper (Canon glossy paper GP-301)
 High gloss film (Canon high gloss Photo Film HG-201)
 High resolution paper (Canon high resolution paper HR-101)
 T-shirt transfers (Canon T-shirt transfers TR-201)
 Fabric (Fabric sheet FS-101)
 Banner (Banner paper)

2.3.3 Paper setting

Media	Thickness Lever	Flap Position	Max. stacking height
Plain paper	Left	Flat	5 mm (LGL: 10 pages)
Bubble jet paper	Left	Flat	5 mm
Envelopes	Right	Flat	5
Transparencies	Left	Flat	20 pages
Back Print Film	Left	Flat	10 pages
Glossy Photo paper	Left	Upright	1 page
High gloss film	Left	Flat	1 page
High resolution paper	Left	Upright	5 mm
T-shirt transfers	Left	Flat	1 page
Fabric Sheet	Right	Flat	1 page
Banner paper	Left	Upright	1 page

2.3.4 Printable area

1) Plain paper and special media

The shaded portion in the diagram below shows the printable area and recommended printing area for paper and special media.

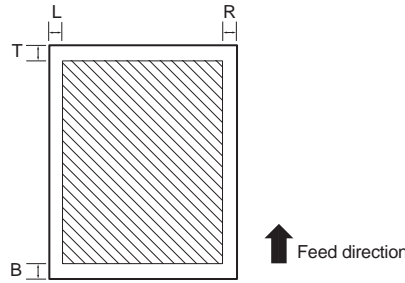

Printable Area Minimum

L	3.4 mm	0.13" ^{*1}
R	3.4 mm	0.13"
T	3.0 mm	0.12"
B	7.0 mm	0.27"

Recommended Printing Area Minimum

L	3.4 mm	0.13" ^{*1}
R	3.4 mm	0.13"
T	20.5 mm	0.81"
B	20.5 mm	0.81"

*1:LTR size: L is 6.4mm(0.25") minimum.

Figure 2-7 Printing Area

2) Envelope

The shaded portion in the diagram below shows the printable area and recommended printing area for U.S. Commercial 10 envelopes (9.5 × 4.1 inches) and

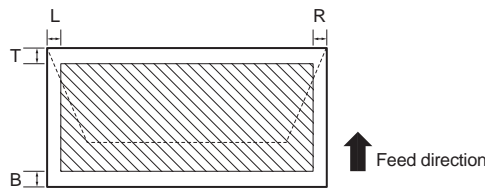

Printable Area Minimum

L	6.4 mm	0.25"
R	10.4 mm	0.41" ^{*1}
T	3.0 mm	0.12"
B	7.0 mm	0.27"

Recommended Printing Area Minimum

L	6.4 mm	0.25"
R	10.4 mm	0.41" ^{*1}
T	20.5 mm	0.81"
B	20.5 mm	0.81"

*1:For Commercial number 10 envelopes,31.4mm(1.2").

Figure 2-8 Printing Area (Envelope)

European DL-size envelopes (229 × 110 mm).

3) Banner paper

The shaded portion in the diagram below shows the printable area and recommended printing area for U.S. Commercial 10 envelopes (9.5 × 4.1 inches) and European DL-size envelopes (229 × 110 mm).

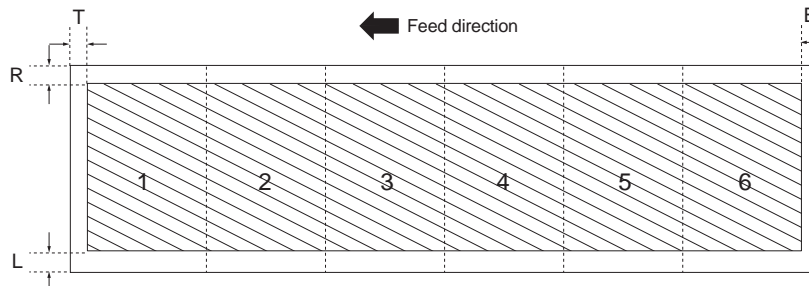

Printable Area Minimum

L	3.4 mm	0.13"
R	3.4 mm	0.13"
T	3.0 mm	0.49"
B	40.0 mm	1.57" ^{*1}

Recommended Printing Area Minimum

L	3.4 mm	0.13"
R	3.4 mm	0.13"
T	20.5 mm	0.49"
B	40.0 mm	1.57" ^{*1}

*: When printing 6 pages

Figure 2-9 Printing Area (Banner Paper)

2.4 Interface Specifications

The printer's interface is designed to support compatible, nibble, and ECP mode, which conform to the bi-directional centronics interface standards (IEEE P1284).

Compatible mode uses the same protocols as those protocols which conform to the conventional centronics interfaces. When this printer works as a printer, data transfer is available only in compatible mode, and not in nibble or ECP mode, both of which allow high-speed data communication. The nibble and ECP modes are used, when the printer is in operation, for transferring status data such as printer's device ID and printer status to the host computer. They are also used, when the scanner is in operation, for communicating the data read from the optional scanner cartridge to the host computer, provided that it also is set in nibble or ECP mode.

The parallel interface sends 8 bits (one byte) of data at a time and is transistor-transistor-logic (TTL) compatible.

The interface cable must be constructed of American Wire Gauge (AWG) No. 28 or larger. The maximum length of the twisted-pair shielded cable must be 2.0 m (approximately 6.6 feet).

1) Interface Type

IEEE1284 compatible parallel interface

2) Data transfer

8-bit parallel interface

3) Signal voltage levels

Low: 0.0 V to +0.8 V

High: +2.4 V to +5.0 V

4) Input/ output

Each signal pulled up with +5V.

5) Interface cable

Type: Twisted-pair double shielded cable

Material: AWG#28 or larger

Length: Up to 2.0 m (6.6 feet)

6) Interface connectors

On printer: Amphenol 57-40360 (or equivalent)

On cable: Amphenol 57-30360 (or equivalent)

7) Input/ output signals and pin layout

Compatible mode

No.	Signal	I/O	No.	Signal	I/O
1	$\overline{\text{STROBE}}$	IN	19	$\overline{\text{STROBE}}\text{-GND}^{\ast 1}$...
2	DATA1	IN	20	DATA1-GND	...
3	DATA2	IN	21	DATA2-GND	...
4	DATA3	IN	22	DATA3-GND	...
5	DATA4	IN	23	DATA4-GND	...
6	DATA5	IN	24	DATA5-GND	...
7	DATA6	IN	25	DATA6-GND	...
8	DATA7	IN	26	DATA7-GND	...
9	DATA8	IN	27	DATA8-GND	...
10	$\overline{\text{ACKNLG}}$	OUT	28	$\overline{\text{ACKNLG}}\text{-GND}$...
11	BUSY	OUT	29	BUSY-GND	...
12	P.E.	OUT	30	$\overline{\text{INT}}\text{-GND}$...
13	$\overline{\text{SELECT}}$	OUT	31	$\overline{\text{INIT}}$	IN
14	$\overline{\text{AUTO FEED XT}}$	IN	32	$\overline{\text{ERROR}}$	OUT
15	N.C. ^{*2}	...	33	GND	...
16	GND	IN	34	N.C. ^{*2}	...
17	GND	...	35	+5.0V ^{*4}	...
18	+5.0V ^{*3}	...	36	$\overline{\text{SELECT IN}}$	IN

*1. All-GNDs are connected to GND.

*2. N.C. means no connection.

*3. The level is pulled up with +5.0V through 3.3k Ω resistor.

*4. The level is pulled up with +5.0V through 390 Ω resistor.

Nibble mode

No.	Signal	I/O	No.	Signal	I/O
1	HostClk	IN	19	Signal Gnd	...
2	Data1	IN/OUT	20	Signal Gnd	...
3	Data2	IN/OUT	21	Signal Gnd	...
4	Data3	IN/OUT	22	Signal Gnd	...
5	Data4	IN/OUT	23	Signal Gnd	...
6	Data5	IN/OUT	24	Signal Gnd	...
7	Data6	IN/OUT	25	Signal Gnd	...
8	Data7	IN/OUT	26	Signal Gnd	...
9	Data8	IN/OUT	27	Signal Gnd	...
10	PtrClk	OUT	28	Signal Gnd	...
11	PtrBusy	OUT	29	Signal Gnd	...
12	AckDataReq	OUT	30	Signal Gnd	...
13	Xflag	OUT	31	$\overline{\text{Init}}$	IN
14	HostBusy	IN	32	$\overline{\text{DataAvail}}$	OUT
15	N.C. ^{*1}	...	33	GND	...
16	Gnd	...	34	N.C. ^{*1}	...
17	Gnd	...	35	+5.0V ^{*3}	...
18	+5.0V ^{*2}	...	36	1284Active	IN

*1. N.C. [Non Connection]

*2. The level is pulled up with +5.0V through 3.3k Ω resistor.

*3. The level is pulled up with +5.0V through 390 Ω resistor.

ECP mode

No.	Signal	I/O	No.	Signal	I/O
1	HostClk	IN	19	Signal Gnd	...
2	Data1	IN/OUT	20	Signal Gnd	...
3	Data2	IN/OUT	21	Signal Gnd	...
4	Data3	IN/OUT	22	Signal Gnd	...
5	Data4	IN/OUT	23	Signal Gnd	...
6	Data5	IN/OUT	24	Signal Gnd	...
7	Data6	IN/OUT	25	Signal Gnd	...
8	Data7	IN/OUT	26	Signal Gnd	...
9	Data8	IN/OUT	27	Signal Gnd	...
10	PeriphClk	OUT	28	Signal Gnd	...
11	PeriphAck	OUT	29	Signal Gnd	...
12	AckReverse	OUT	30	Signal Gnd	...
13	Xflag	OUT	31	ReverseReq	IN
14	HostAck	IN	32	PeriphReq	OUT
15	N.C. ^{*1}	...	33	GND	...
16	Gnd	...	34	N.C. ^{*1}	...
17	Gnd	...	35	+5.0V ^{*3}	...
18	+5.0V ^{*2}	...	36	1284Active	IN

*1. N.C. [Non Connection]

*2. The level is pulled up with +5.0V through 3.3k Ω resistor.

*3. The level is pulled up with +5.0V through 390 Ω resistor.

8) Input/ output signals:**Compatible Mode****STROBE [Input]**

This signal is used to read DATA1 to DATA8. The signal becomes valid after BUSY signal goes Low and the printer outputs an ACKNLG signal. The host computer does not send the next signal until it receives ACKNLG signal. It is normally High, after becoming Low, the printer receives data. When the signal remains Low, the printer does not operate until it goes High.

DATA1 to 8 [Input]

The printer receives data with the STROBE signal. The state of each bit of the signal must be maintained for at least 0.5 μ s from the rising edge of the STROBE signal.

ACKNLG [Output]

This signal is a response signal to the STROBE signal. The host computer does not send the next STROBE signal until this signal is sent. When the power is turned on or the BUSY signal goes Low for the input of the INIT signal, this signal is sent regardless of the STROBE signal.

BUSY [Output]

When this signal is High, the printer is BUSY; when Low, the printer is READY. The signal goes high when data is received, when the printer is offline, or when an error occurs (paper-out, paper jam).

P.E. [Output]

When the printer cannot feed paper, this signal goes High. Then BUSY signal goes High and the SELECT and FAULT signals go Low. The signal goes Low when the paper is set and the printer goes online. FAULT and SELECT signals then go High from Low. If paper is not ejected (paper jam) by executing a paper eject command, this signal and BUSY signal go High, and SELECT and FAULT go Low. In this case, the signals do not change even if the paper is ejected.

SELECT [Output]

The printer is SELECT when this signal is High. The printer is DESELECT when this signal is Low. This signal goes Low when the printer is offline, when an error occurs (paper-out, paper jam, head error, etc.).

AUTO FEED XT [Input]

Not used.

INIT [Input]

INIT from the system resets the printer to its initial power-on state. In BJ mode, the BUSY line goes High, and any received data is printed. In LQ mode, the BUSY line goes High, and the print buffer is cleared. When INIT goes Low, it resets the printer to the power-on default state.

FAULT [Output]

This signal goes Low when the printer is in an error state [paper-out, paper jam, etc.).

SELECT IN [Input]

Not used.

Nibble Mode**Host Clk [Input]**

$\overline{\text{STROBE}}$ signal to read DATA 1 to DATA 8.

Negotiation phase:

Trigger signal to send the protocol confirmation to the printer.

DATA 1-8 [Input]

The printer receives data with the Host Clk signal.

The state of each bit of this signal must be maintained for at least 0.5 μs from the rising edge of the Host Clk signal.

Ptr Clk [Output]

Reverse data transmission phase:

The printer requests the host computer to read the data by making the Ptr Clk Signal Low. After finishing reading, the host computer notifies peripheral equipment of completion of data receiving by making the Host Busy signal High.

Ptr Busy [Output]

Reverse data transmission phase:

Indicates bit 3 and bit 7 of the transmission data.

Ack Data Req [Output]

- Reverse data transmission phase:

Indicates bit 2 and bit 6 of the transmission data.

- Negotiation phase:

Trigger signal to inform the host computer of the printer's condition [whether it supports nibble mode or not, whether there is reverse transmission data or not].

Xflag [Output]

- Reverse data transmission phase:

Indicates bit 1 and bit 5 of the transmission data.

- Negotiation phase:

Informs the host computer whether the printer supports nibble mode or not, synchronizing with the falling edge of the Ack data Req signal. "L" means that it supports nibble mode.

Host Busy [Input]

- Reverse data transmission phase:

Indicates that the host is ready to receive the data from the printer by making the Host Busy signal Low. After that, it goes high to synchronize with the Low pulse of Ptr Clk signal to verify receiving data.

- Reverse idle phase:

The Host Busy signal goes high in response to the Low pulse of the Ptr Clk signal, and enters the reverse data transmission phase again.

 $\overline{\text{INIT}}$ [Input]

When this signal becomes "L," the printer's state becomes BUSY. When the signal changes from "L" to "H," it resets the printer control system to the initial state.

This signal is normally "H" and the pulse width must be at least 0.5 μs at the printer side.

After initializing, the printer enters compatible mode.

DataAvail [Output]

- Reverse data transmission phase:

Indicates bit 0 and bit 4 of the transmission data.

- Negotiation phase:

Informs the host computer if there is reverse transmission data or not to synchronize with the falling edge of the Ack Data Req signal. "L" means that there is reverse transmission data.

1284 Active [Input]

This signal confirms that the printer is a 1284 compatible device when 1284 Active signal goes High and Host Busy signal goes Low. It goes Low with the termination phase.

ECP Mode**Host Clk [Input]**

This signal handshakes with the PeriphAck signal when data is transferred from the host computer to the printer. A Low Host Clk signal indicates that data has been output along the data buses (Data1-8).

The signal goes High as a response to a High PeriphAck signal. It remains High during reverse data transmission.

Data 1-8 [Input/Output]

This signal is an input signal when data is transferred from the host computer to the printer. During reverse data transmission, this is an output signal and the printer uses this data bus to send data to the host computer.

Periph Clk [Output]

When data is transferred from the printer to the host computer, this signal remains High. Periph Clk signal is lowered during reverse transmission phase and indicates that data has been sent to the host computer. This signal is also High in response to the High HostAck signal from the host computer.

Periph Ack [Output]

Periph Ack signal goes Low when the printer is ready to receive data from the host computer. Once the data is received the signal goes High. During the reverse data transmission phase, this signal indicates whether the data sent from the printer to the data bus was "command" or "data."

Low: "Command," High: "Data"

Ack Reverse [Output]

Ack Reverse signal remains High when data is transferred from the host computer to the printer. During the reverse data transmission phase, the signal remains Low. The Reverse Request signal from the host computer goes Low to request a switch from the forward data transmission phase to the reverse data transmission phase. In response to the Low Reverse Request signal, Ack Reverse signal goes low to indicate that the request was accepted.

When the Reverse Request signal from the host computer goes High to request a switch from the reverse data transmission phase to forward data transmission phase, Ack Reverse signal goes High to indicate the switch over request has been accepted.

X flag [Output]

This signal remains High in ECP mode.

Host Ack [Input]

This signal indicates the nature of the signal along the data bus when data is transferred from the host computer to the printer. A Low Host Ack indicates "command" whereas a High Host Ack indicates "data."

During reverse data transmission, this signal handshakes with the Periph Clk signal. When the host computer is ready to accept data from the printer, this signal goes Low. After data is received the signal goes High.

Reverse Req [Input]

This signal goes Low when the recovery process (data re-transmission) is taking place during data transmission from the host computer to the printer.

In response to a Low Ack Reverse signal, Reverse Req signal goes High.

When switching from the idle state of the forward data transmission phase to the reverse data transmission phase, i.e. data is transferred from the printer to the host computer, this signal goes Low.

The Low period indicates it is in the reverse data transmission phase.

When the reverse data transmission phase is switched to the forward data transmission phase, this signal goes High.

Periph Req [Output]

If the printer requests reverse data transmission during the forward data transmission, this signal goes Low. When the host computer switches over from the forward data transmission phase to the reverse data transmission phase, together with the Ack Reverse signal, the Periph Req signal goes High in response to the host computer's Low Reverse Request signal.

1284 Active [Input]

During the negotiation phase, this signal goes High and remains High during ECP mode to indicate bidirectional operation.

After ending ECP mode, this signal goes Low and enters the termination phase.

9) Timing**Compatible Mode**

The parallel interface for compatible mode transfers data in 8-bit units. Data is transferred with the STROBE, BUSY, and ACKNLG handshake signals.

When the printer receives the data (Data 1-8) and STROBE signal from the host computer and the STROBE signal is Low, the printer controller (which controls the parallel interface) outputs the BUSY signal and latches the data. After the BUSY signal is output, the printer controller sends the latched data from the DRAM bus to the receive buffer in the DRAM. After the data is completely written into the receive buffer in the DRAM, the printer controller outputs the ACKNLG signal and sets the BUSY signal to "Low." Then it waits for the next data input from the host computer.

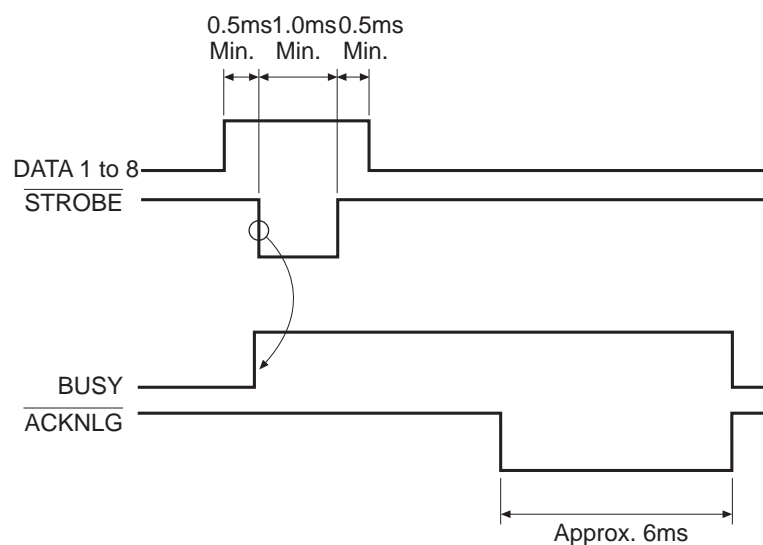

Figure 2-10 Timing Chart (Compatible Mode)

Nibble mode

In nibble mode, the printer transfers data twice to the host computer in 4-bit units. The data is transferred with the PtrClk signal and HostBusy signal handshakes. After the printer confirms that the HostBusy signal is Low, it prepares 8-bit data, lowers the PtrClk signal and outputs the lower 4-bits along the control signal line. After the PtrClk signal is Low, the host computer receives the data and raises the HostBusy signal. Next, after the printer confirms that the HostBusy signal is Low for a second time, it outputs the upper 4-bits along the control signal line. If there is no data to be sent to the host computer after the HostBusy signal is High, the DataAvail signal becomes High and the printer stands by for the next data transfer.

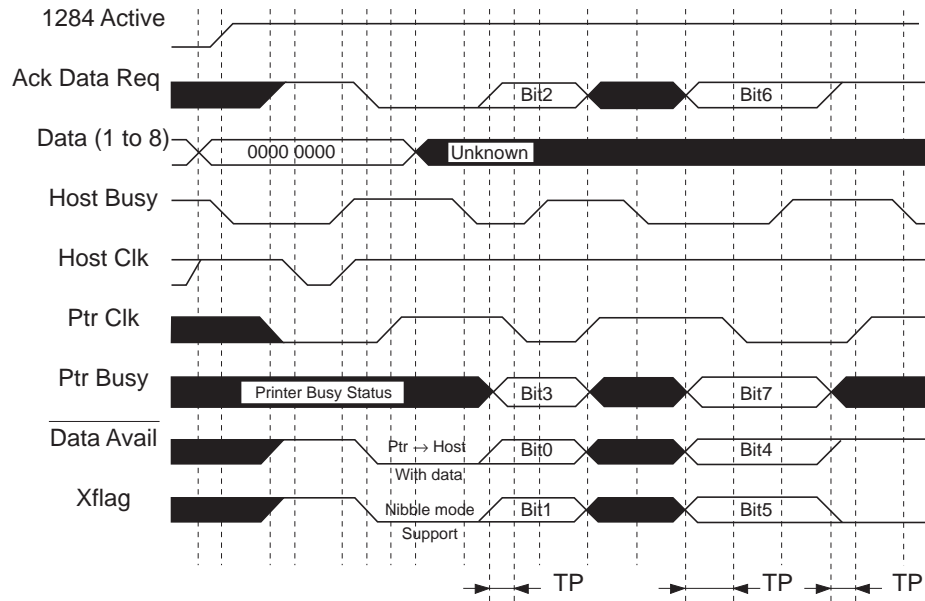

Figure 2-11 Timing Chart (Nibble Mode)

ECP mode

In ECP mode, the printer transfers data at once in 8-bit units allowing faster data transmission and reception. This mode is suitable for large data transfers such as for scanners.

After the computer responds to the Low Reverse Request signal, the AckReverse signal goes Low and the data bus direction switches from the forward data transmission phase (host computer to printer) to the reverse data transmission phase (printer to host computer).

During the reverse data transmission phase, the HostAck signal confirms that the PeriphClk is High before it goes Low. HostAck signal goes Low when the printer is ready to receive data from the host computer. The host computer raises the HostAck signal after it receives the data.

During reverse data transmission, a high PeriphAck signal represents "data" whereas a Low signal represents a "command."

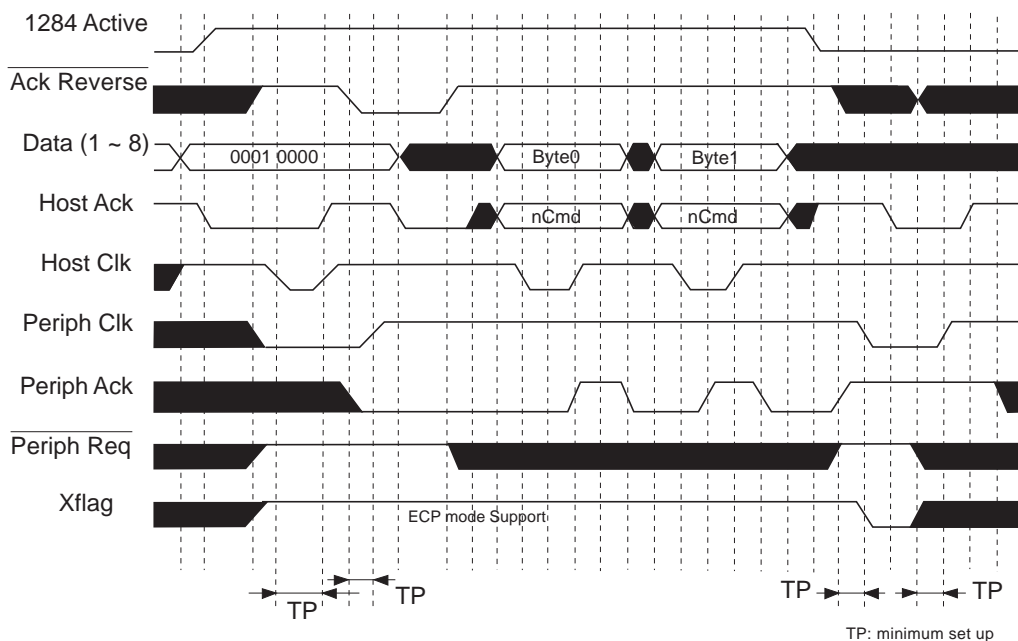

Figure 2-12 Timing Chart (ECP Mode)



Part 3

OPERATING INSTRUCTIONS

Page	
3 - 1	1. PRINTER SETUP
3 - 1	1.1 Equipment Check
3 - 2	1.2 Printer Dimensions
3 - 3	1.3 Setup Procedure
3 -10	1.4 Turning the Printer On/Off
3 -11	1.5 Paper Settings
3 -11	1.6 Banner Printing
3 -12	1.7 Scanning Precautions
3 -13	1.8 Name of the Parts and Their Functions
3 -15	2. PRINTER SERVICING FUNCTIONS
3 -15	2.1 Error Indications
3 -17	2.2 Cleaning the BJ Cartridge
3 -17	2.3 Self-Test Printout
3 -19	2.4 EEPROM Reset

1. PRINTER SETUP

1.1 Equipment Check

After unpacking the printer, make sure the items below are included:

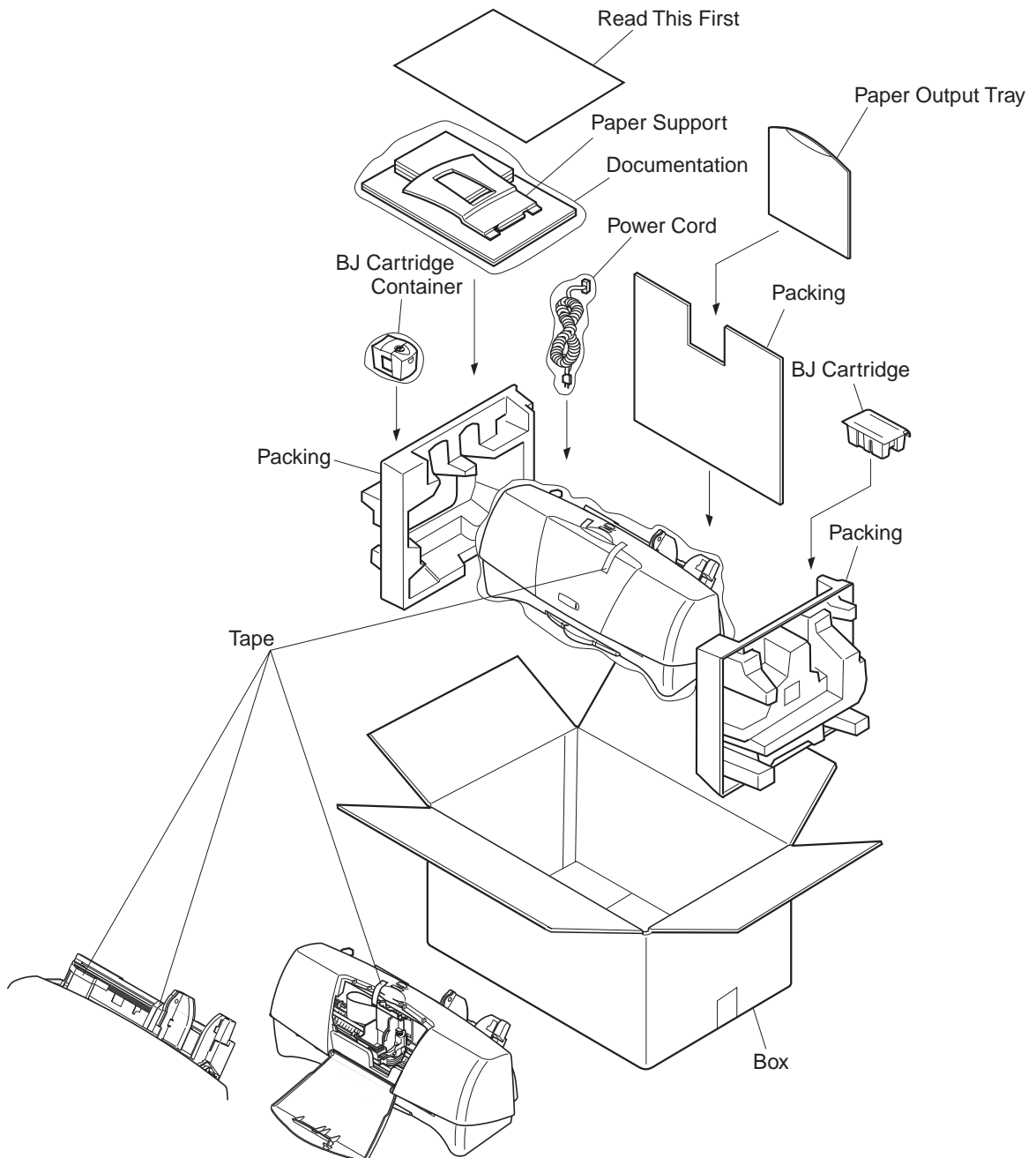

Figure 3-1 Packaging

1.2 Printer Dimensions

The printer's dimensions are shown below. Allow enough space for the printer to be used with ease.

For banner printing leave a space about the size of two A4-size papers in front of the printer. Also allow enough space at the back of the printer to set the banner paper.

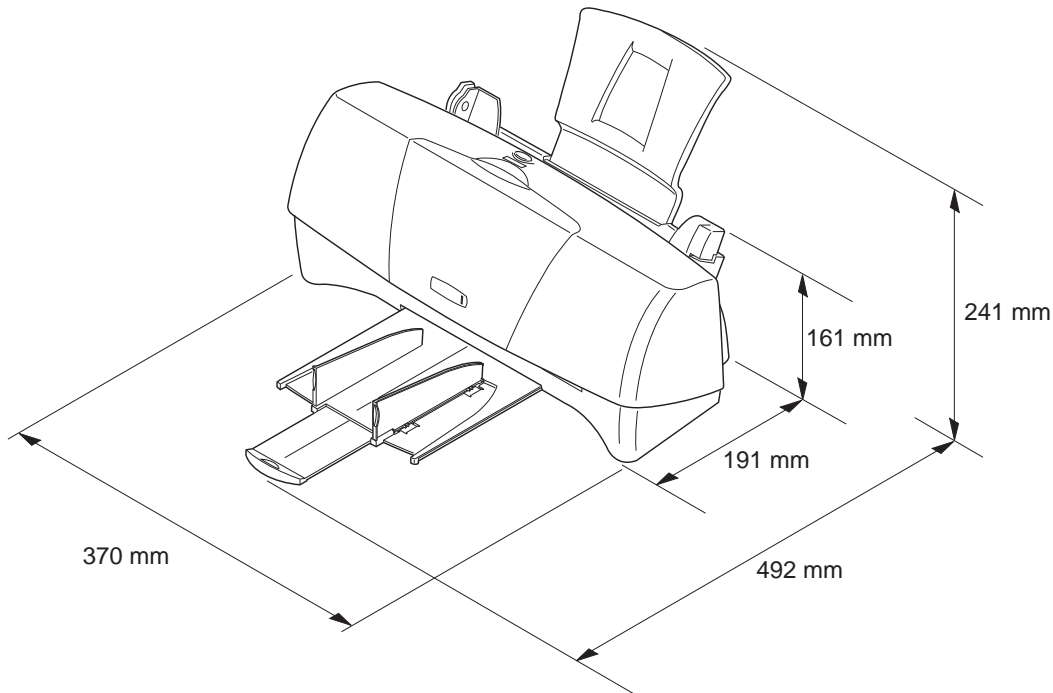

Figure 3-2 Printer Dimension



-
- Do not place the printer in excessive heat or humidity.
 - Operate the printer under the following conditions:
 - Ambient temperature: 5°C to 35°C
 - Relative humidity: 10% to 90% (no condensation)
 - Do not place the printer in direct sunlight.
 - Do not place the printer near a device containing a magnet or generating a magnetic field.
 - Place the printer on a level and stable surface.
 - Do not place the printer in areas subject to vibration.
 - Keep the printer clean.
 - When moving the printer, hold both ends.
-

1.3 Setup Procedure

Set up the printer as follows.

1.3.1 Connecting the interface cable

- 1) Make sure that the printer's power cord is disconnected and the computer's power is turned off.
- 2) Connect one end of the parallel interface cable to the parallel interface connector on the back of the printer.
After connecting the cable, fasten the locking arms to secure it.
- 3) Connect the other end of the interface cable to the parallel interface connector on the computer.

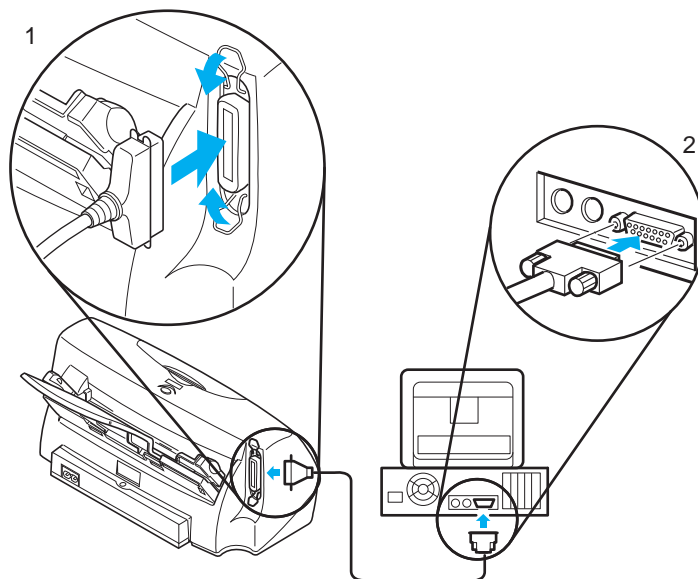

Figure 3-3 Connecting the Interface Cable

1.3.2 Turning on the printer

The printer turns on when the AC plug is plugged in.

Before turning on the printer, first turn on the computer and any other peripheral equipment. When turned on, the printer executes initializing operations. Finally, the carriage stops at the cartridge replacement position.

1.3.3 Installing the cartridge

Two types of cartridges can be installed in the printer: a color and black BJ cartridge.

1) Removing the BJ cartridge protectors

Take out the BJ cartridge from the package, then remove the cap protecting the nozzles and gently peel off the protective tape as shown in the figure.

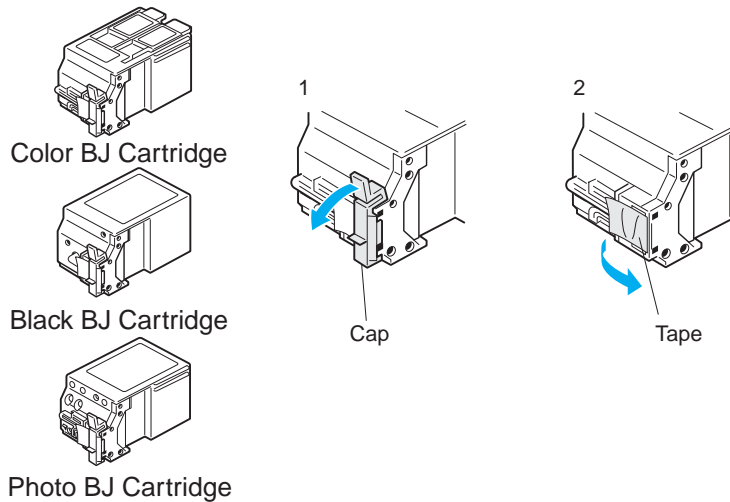

Figure 3-4 Removing the BJ Cartridge Protectors



Do not unpack the BJ cartridge until it is ready to be used.

Do not reuse the cap and tape, as doing so can clog the nozzles or mix the ink colors.

Do not touch the nozzles when removing the tape. Scratching the head face and ink contamination may result in poor printing.

Never touch or wipe the nozzles with tissue paper, etc. to prevent them from clogging.

To prevent foreign matter or dried ink from clogging the nozzles, install the BJ cartridge immediately in the printer or in the cartridge container after removing the cap and peeling off the tape.

Clogged nozzles can cause white streaks across printed area. If this problem persists even after the ink cartridge is cleaned by the printer, replace the BJ cartridge.

Do not shake the BJ cartridge after removing the cap and tape, as ink may leak from the cartridge.

Do not store color BJ cartridges with the ink cartridges removed. BJ cartridges cannot be disassembled, reassembled, or washed.

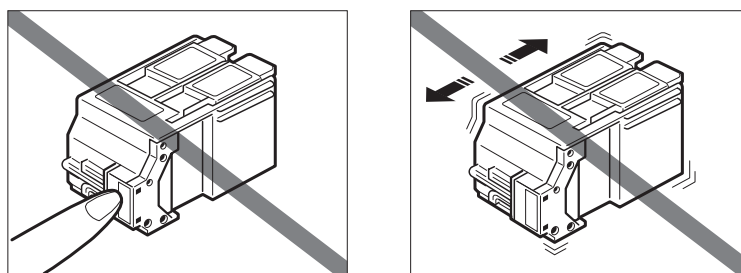

Figure 3-5 BJ Cartridge Handling Precautions

2) Installing the cartridge

Open the printer's front cover and flip up the cartridge lock lever. Insert the cartridge into the carriage and push down the cartridge lock lever to lock the cartridge in place. When the front cover is closed, the carriage moves to the capping position.



When installing the scanner cartridge, all the LEDs are lit at 75% power output at the home position for a max. of 100 sec., and preheated to stabilize the LED output. The computer will display a message saying "Warming up scanner cartridge. Please wait." will appear. After the message appears, all the LEDs are lit at 50% power output for a max. of 600 sec. to retain the temperature.

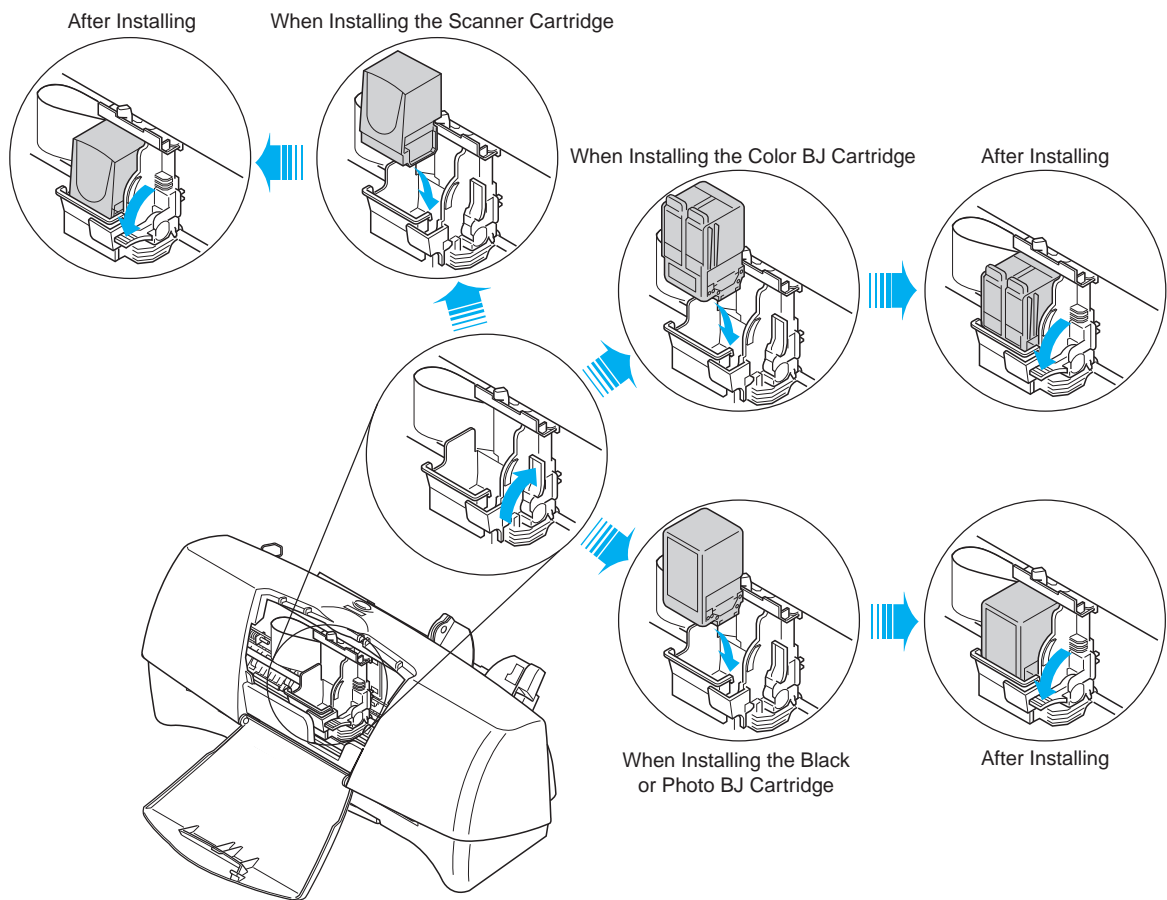

Figure 3-6 Cartridge Installation

3) Replacing the cartridge

Open the printer's front cover and the carriage moves to the replacement position. Then flip up the cartridge lock lever and remove the cartridge. Install another cartridge by following "Installing the cartridge" above. Always store an unused BJ cartridge in the BJ cartridge container. The scanner cartridge should be stored in the soft case. The BJ cartridge may be stored alternately in the BJ cartridge container.



If the printer has been operating for a prolonged period, the BJ cartridge's aluminum plate will get hot. When the aluminum plate becomes too hot, the carriage will not move to the cartridge replacement position. In this case, close the front cover, and wait for a few minutes before replacing the BJ cartridge. Do not move the carriage by hand.

1.3.4 Scanner cartridge precautions

Do not touch the scanning head of the scanner cartridge as it may affect the quality and ability of the scanning operation. When cleaning the scanner lens, wipe gently with a soft damp cloth and wipe off any excess moisture with a soft dry cloth or paper. To avoid damage caused by miscontact or static charge, do not touch the contact terminals. The scanner cartridge cannot be disassembled, reassembled, or washed.

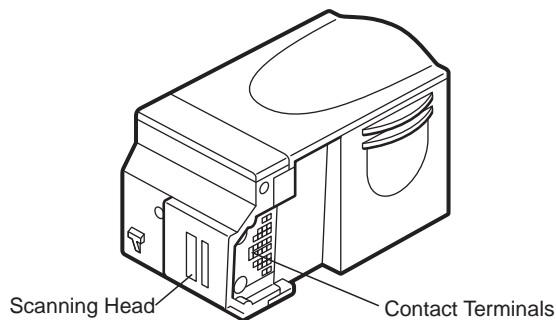

Figure 3-7 Scanner Cartridge

1.3.5 Replacing the ink cartridge

When the color BJ cartridge is used, the ink cartridges can be replaced as follows:

1) When to replace the ink cartridge

Replace the ink cartridge in any of the following cases: the ink has run out, the ink cartridge has been out of its package for over six months, or the print quality does not improve even after the cartridge is cleaned five times. The color ink cartridge contains three colors. If one ink color runs out, the entire color ink cartridge must be replaced.

If an ink cartridge has been replaced but the print quality does not improve even after cleaning, replace the color BJ cartridge with a new one.

2) Removing an ink cartridge

Open the front cover and the carriage moves to the cartridge replacement position. Then take out the ink cartridge to be replaced as shown in the figure below.



Ink adheres to and around the ink cartridge's ink inlet, so handle the cartridge with care.

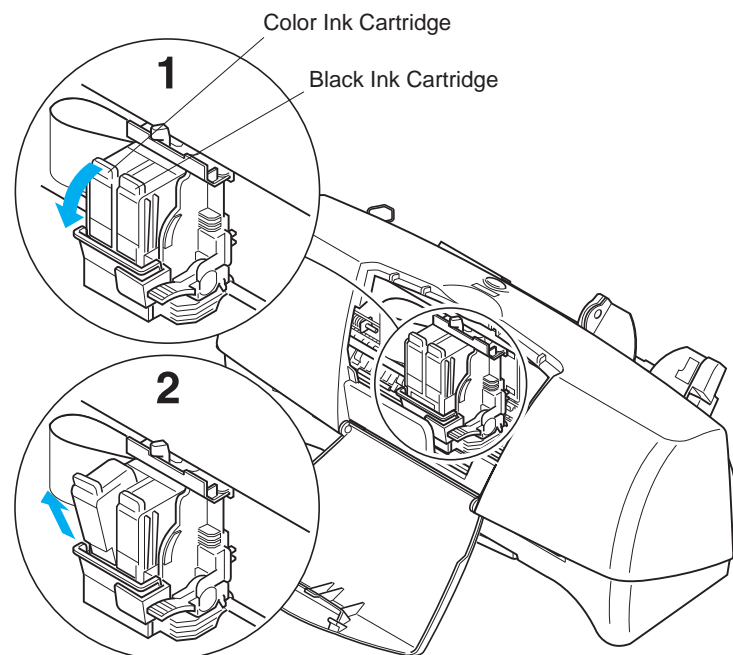

Figure 3-8 Removing the Ink Cartridge

3) Installing an ink cartridge

Take out the new ink cartridge from its package and remove the cap covering the ink outlets as shown in the figure. Install the ink cartridge by following the removal procedure in reverse.

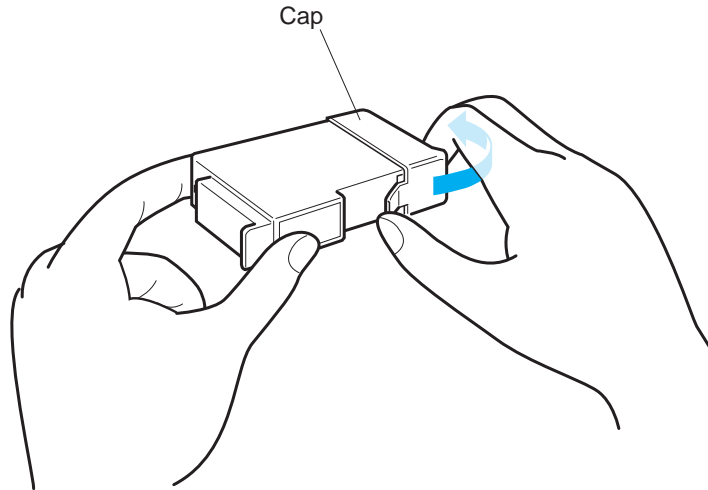

Figure 3-9 Removing the Ink Cartridge Cap



Do not unpack the ink cartridge until it is ready to be used. To prevent poor ink suction due to clogging of the joint pipes, never touch the ink cartridge's ink outlets. After removing the cap from the ink cartridge, promptly install the ink cartridge in the BJ cartridge to prevent the nozzles from clogging due to dried-out ink and dust, etc. Do not remove an ink cartridge from the BJ cartridge unless replacing.

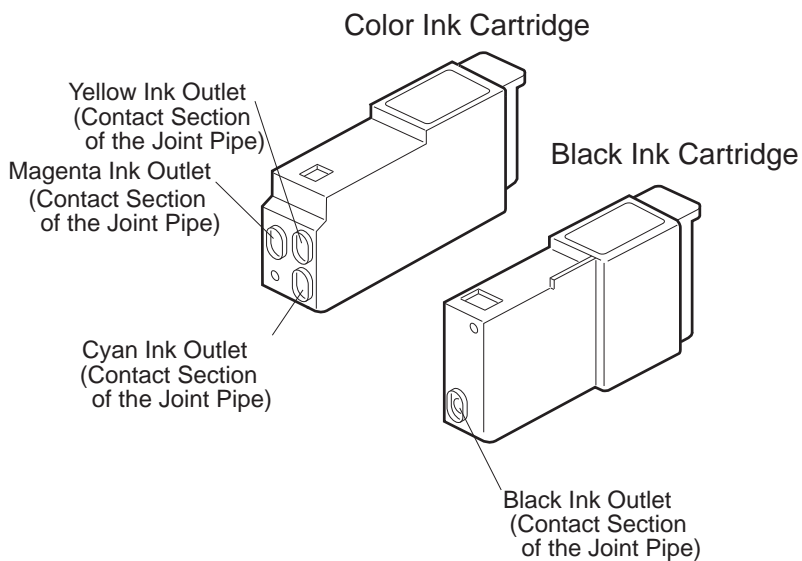

Figure 3-10 Ink Cartridge Protection

1.3.6 BJ cartridge container

A BJ cartridge container for storing the BJ cartridge is packed with the printer. Always store an unused BJ cartridge in the BJ cartridge container. The box can store one BJ cartridge only, but several containers can be joined together.



The BJ cartridge container can be attached to the printer. When storing a color BJ cartridge make sure that the black and color ink cartridges are installed.

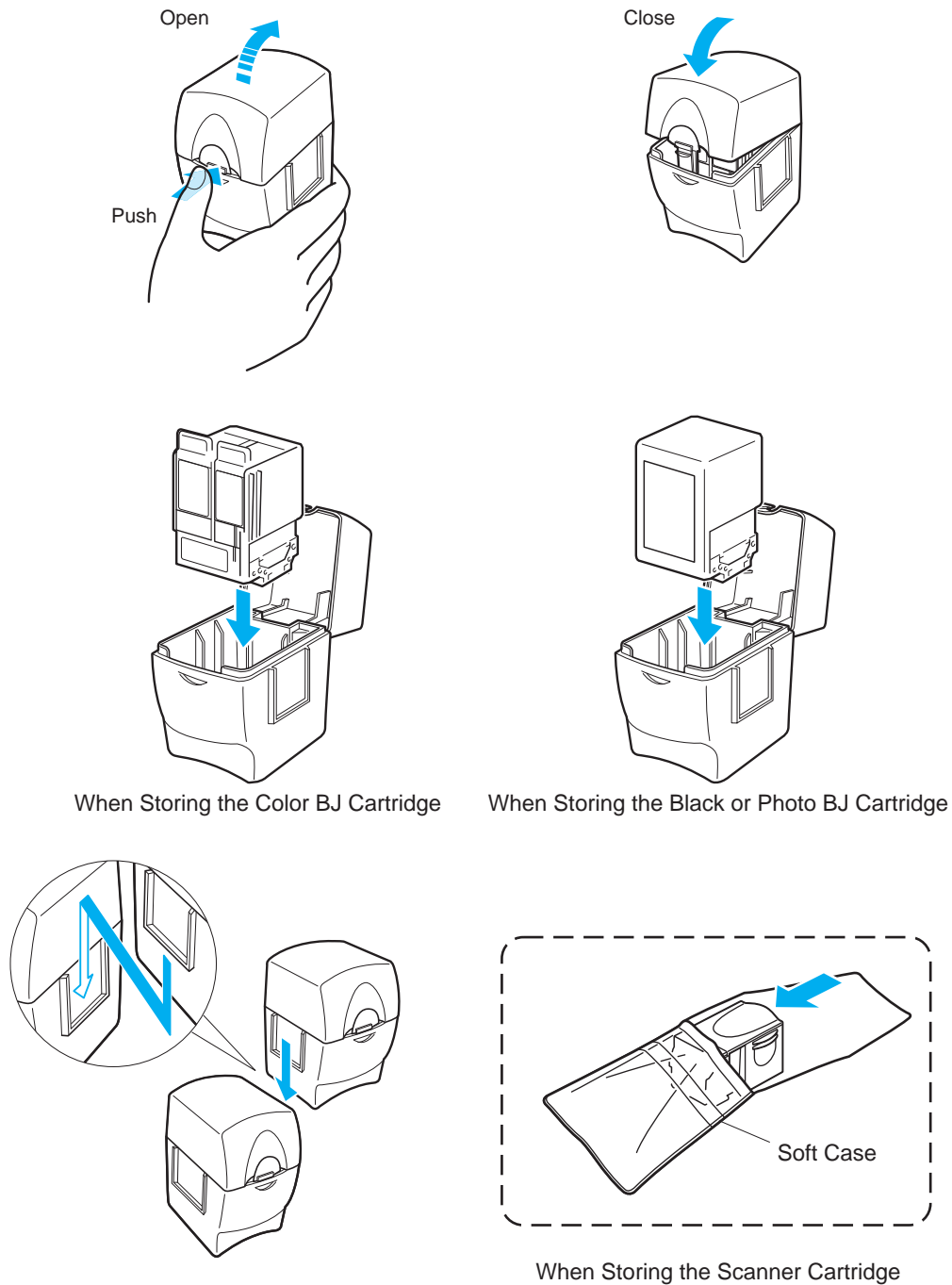

Figure 3-11 BJ Cartridge Container

1.4 Turning the Printer On/Off

1.4.1 Turning the printer on

Connect the power cord to a power source to turn on the printer, and initializing operations are executed. If a cartridge has not been installed, the carriage will move to the cartridge replacement position.

1.4.2 Turning the printer off

Unplug the power cord from the power source to turn off the printer. When unplugging the power cord, wait at least one minute after completing an operation such as printing, feeding paper, cleaning the print head, etc.



Never unplug the power cord less than one minute after completing an operation. Otherwise, the BJ cartridge will not be capped. In such case, ink may leak or dry out in the nozzle.

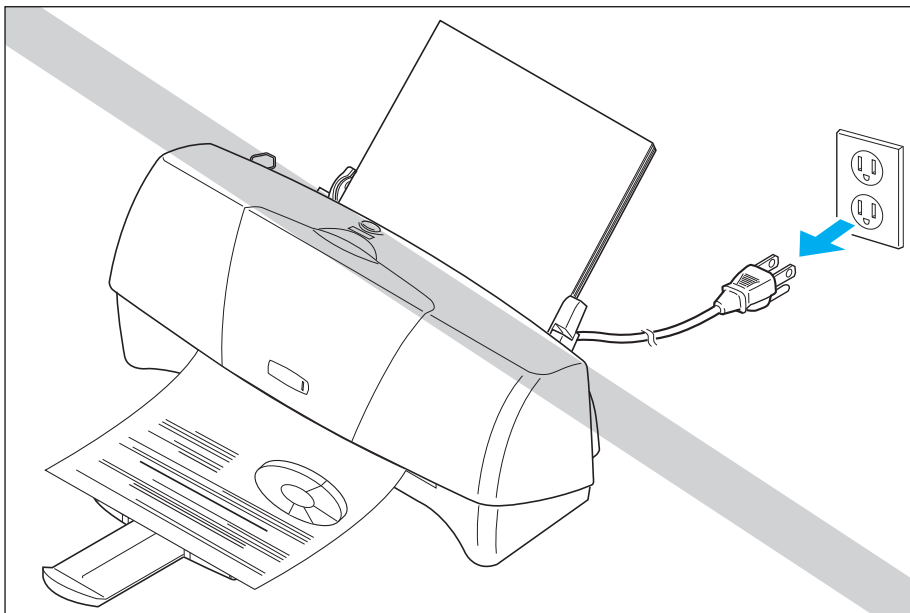

Figure 3-12 Never unplug the power cord less than one minute after completing an operation

1.5 Paper Settings

For optimum printing, the printer has various paper settings to suit various types of paper. Set the paper selection lever before loading the paper.

TABLE 3-1 QUICK REFERENCE FOR SETTING

Media	Thickness Lever	Paper Feed		Flap Position
		Method	Limit	
Plain paper	Left	Sheet feeder	5 mm	Flat
High resolution paper	Left	Sheet feeder	5 mm	Upright
Envelopes	Right	Sheet feeder	5 envelopes	Flat
Transparencies	Left	Sheet feeder	20 sheets	Upright
Back print film	Left	Sheet feeder	10 sheets	Upright
Glossy photo paper	Left	Sheet feeder	1 sheet	Upright
Banner paper	Right	Sheet feeder	1 sheet	Upright
Fabric sheet	Right	Sheet feeder	1 sheet	Upright
High gloss film	Left	Sheet feeder	1 sheet	Upright

1.6 Banner Printing

When printing on banner paper, remove the paper support and set the paper delivery flap to the upright position. To avoid misfeeding, put a light crease between the first and second page and set the first page in the sheet feeder. Place the rest of the banner paper behind the printer. Each top margin for banner printing is set at 0mm.

However, to avoid printing on the platen, printing will start 3mm from the initial top margin. Set an extra sheet at the end in case the bottom edge is not printed on the last page.

Banner printing uses a large amount of ink. To avoid ink shortage, use of a new ink cartridge when printing banners is recommended.

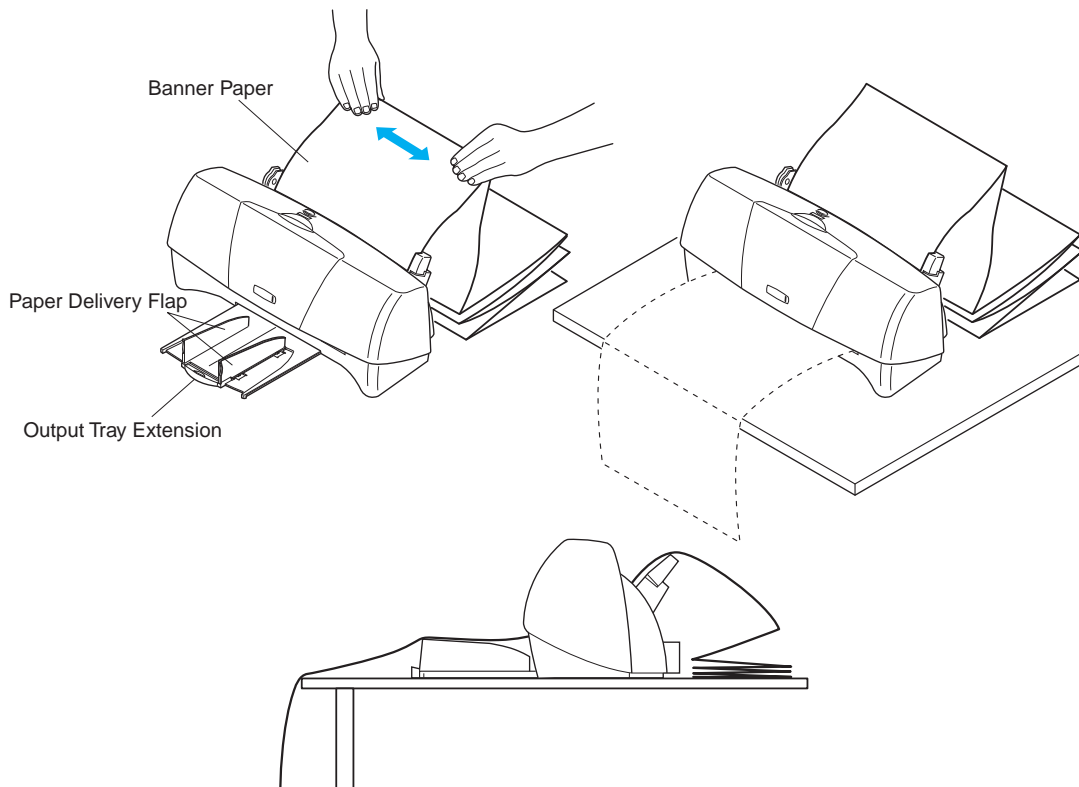

Figure 3-13 Banner Printing

1.7 Scanning Precautions

The scanning document should be placed in the scanning holder to prevent staining or scratching. Do not feed thick or bent paper. Also direct feeding of thin paper or corner-folded paper may result in paper jamming.

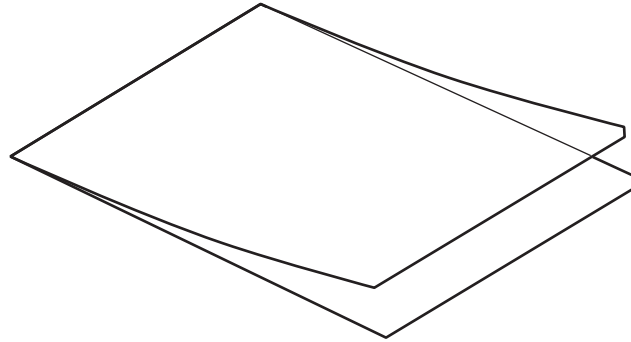

Figure 3-14 Scanning Holder

1.8 Name of the Parts and Their Functions

The different parts of the printer and their functions are shown below.

Paper Support

Supports the stack of paper loaded in the cut sheet feeder.

Cut Sheet Feeder

Holds a stack of approximately 50 cut sheets (64g/cm²) for automatic feeding.

Paper Guide

Aligns the cut sheets in the cut sheet feeder according to the paper size.

Front Cover

Open to install or remove the cartridge, set the paper thickness lever, or remove jammed paper.

Paper Output Tray

Pulls out to receive the printed sheets.

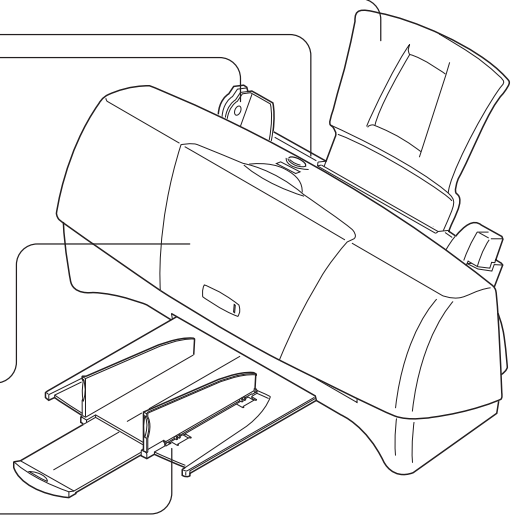

AC Adapter

Installed on the rear of the printer, the AC adapter supplies power from the power outlet to the printer.

Parallel Interface Connector

Connects the printer to the parallel port on the computer.

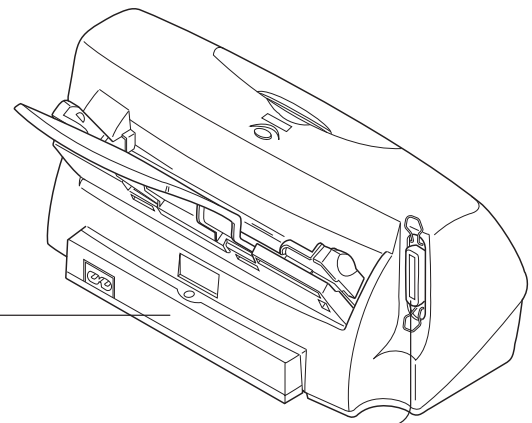

Figure 3-15 Name of the Parts and Their Functions

RESET button

This key has the following functions:

- To recover an error, press and hold down for over two seconds.
- To start cleaning the print head, press and hold down for over two seconds.
- To start the nozzle check pattern, double click.

Paper thickness lever

Adjusts the gap between the printhead and the paper. Set this lever according to the type of print media that you are using.

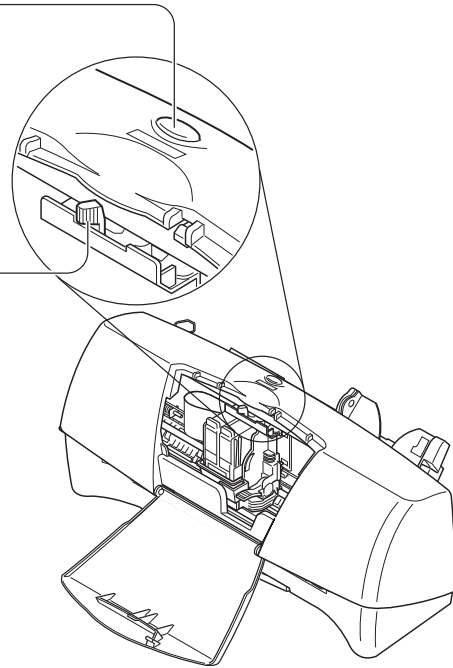

Figure 3-16 Name of the Parts and Their Functions

Paper thickness lever

Adjusts the gap between the print head and paper according to the thickness of the paper. There are two settings: left for plain paper, high resolution paper, transparencies, back print film, glossy paper or high glossy film and scanner cartridge; and right for thick paper, envelopes, and banner paper.

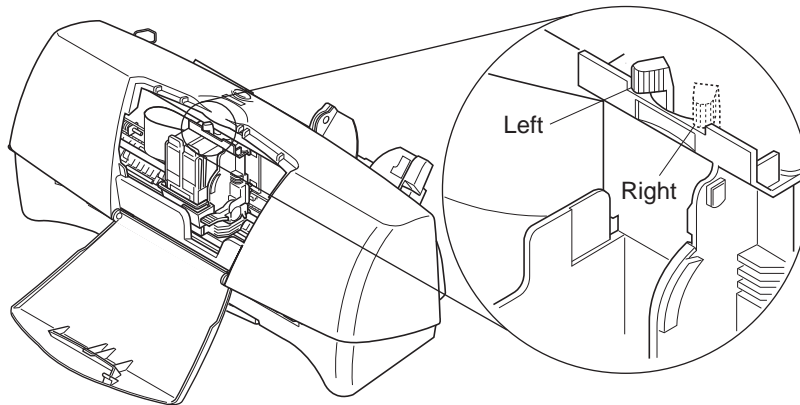

Figure 3-17 Paper Thickness Lever

2. PRINTER SERVICING FUNCTIONS

2.1 Error Indications

Errors will be displayed on the host computer monitor. (The host computer should be set to ECP or Nibble mode and use the BJ status monitor on Windows95.) Main error sentences are shown in the table below:

TABLE 3-2 ERROR INDICATIONS

Error condition	Error indication	Error code
[Recoverable by customers]		
Paper feed	The printer is out of paper.	...
Cover open	The printer's front cover is open.	...
Paper jam	A paper jam has occurred.	...
No cartridge	A BJ cartridge error occurred. Install the BJ cartridge properly and close the printer's front cover.	...
Head mismatch	An incorrect cartridge is installed in the printer.	...
[Unrecoverable by customers]		
Home position error	An error that possibly requires a service call has occurred.	5000
Carriage control error	An error that possibly requires a service call has occurred.	5100
Head temperature (sensor) error	An error that possibly requires a service call has occurred.	5200
Printer temperature sensor error	An error that possibly requires a service call has occurred.	5400
No cartridge error	An error that possibly requires a service call has occurred.	5600
Waste ink full error	The used ink tank is full.	...
Purging operation error	An error that possibly requires a service call has occurred.	5C00
Scanner cartridge error	An error that possibly requires a service call has occurred.	5210

The errors listed in Table 3-2 are described below.

- **Recoverable errors by customers** (Correctable by removing the paper and pressing and holding down the *RESET* button for over two seconds).
 - 1) **Paper feed**
Occurs when the paper cannot be fed properly.
 - 2) **Cover open**
Occurs when the printer's front cover is open.
 - 3) **Paper jam**
Occurs when the printed paper cannot be ejected.
 - 4) **No cartridge**
Occurs when a BJ cartridge is not installed.
 - 5) **Head mismatch**
Occurs when the scanning operation is attempted with a BJ cartridge installed.
Occurs also when attempting printing with a scanner cartridge installed.

- **Unrecoverable errors by customers** (Pull out the AC plug to turn off the power.)
 - 6) **Home position error**
Displayed when the home position can not be detected.
 - 7) **Carriage control error**
Occurs when the print position correction cannot be detected.
 - 8) **Head temperature (sensor) error**
Occurs when the diode sensor in the BJ cartridge head is assessed as irregular.
 - 9) **Printer temperature sensor error**
Occurs when the temperature sensor's (TH1) reading on the control board is irregular.
 - 10) **No cartridge error**
Occurs when the printer does not detect the cartridge other than during cartridge replacement.
 - 11) **Waste ink full error**
Occurs when the "total waste ink amount" recorded by the EEPROM exceeds the prescribed limit.
 - 12) **Purging operation error**
Occurs when the purging operation detection at the capping position is irregular.
 - 13) **Scanner cartridge error**
Occurs when the scanner cartridge is recognized but the scanner ID is incorrect.
Occurs when the calibration data sent from the computer is incorrect.

2.2 Cleaning the BJ Cartridge

Press and hold the *RESET* button for two seconds or more. The cleaning time is approximately 20 seconds.

After the cleaning, execute a test printout of the nozzle check pattern to check the print quality. (Double click the *RESET* button.)

The printer cleans the BJ cartridge automatically at the following times:

- 1) When the printer is turned on for the first time. (When the AC plug is plugged in.)
- 2) After the BJ cartridge is replaced.
- 3) After an ink cartridge is replaced.
- 4) After the printer has been on for 72 hours following the last cartridge cleaning with a black BJ cartridge installed. When the color BJ cartridge or its ink cartridge is installed, only the first cleaning is carried out automatically after 24 hours (after that, cleaning is carried out at an interval of 72 hours).
- 5) After printing a prescribed number of dots.

2.3 Self-Test Printout

This printer has built-in self-test functions which can be executed without any connection to a computer. There are two print modes available in self-test prints: the nozzle check pattern and service test print.



All self-test prints require Letter or A4-size paper. Using smaller sized paper for a self-test print will result in parts of the printout being printed directly on the platen.

2.3.1 Nozzle check pattern

Double click the *RESET* button while the AC plug is plugged in. After printing one page of the nozzle check pattern, the printer stops the test.

On the nozzle check pattern, a pattern using all nozzles, and the control ROM version are printed. In the event that print defects appear, perform a cleaning operation of the head. If print quality does not improve even after the cartridge is cleaned five times, replace the BJ cartridge or the ink cartridge.

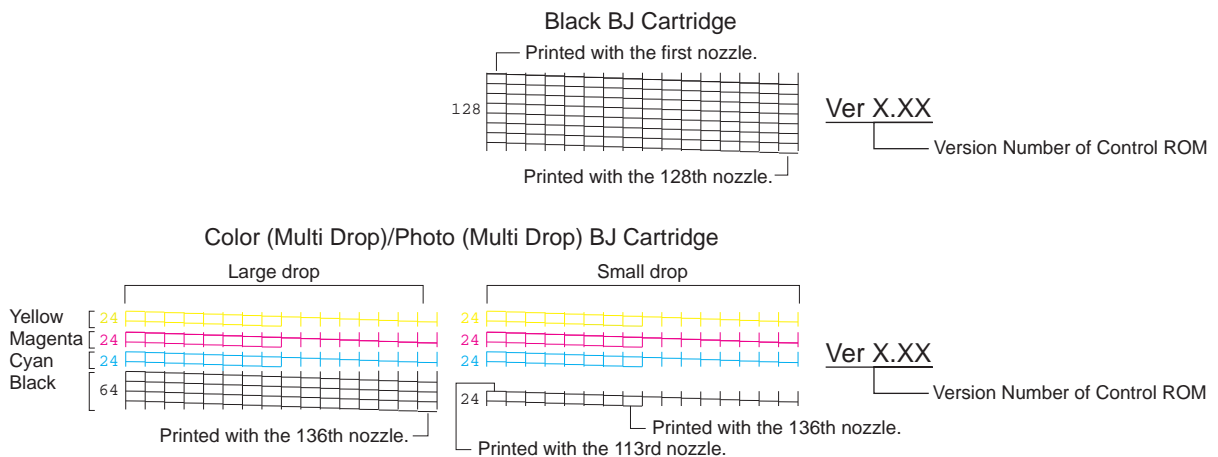

Figure 3-18 Nozzle Check Pattern

2.3.2 Service test print

On the service test print, the control ROM version, and EEPROM (IC1) data are printed, as shown below.

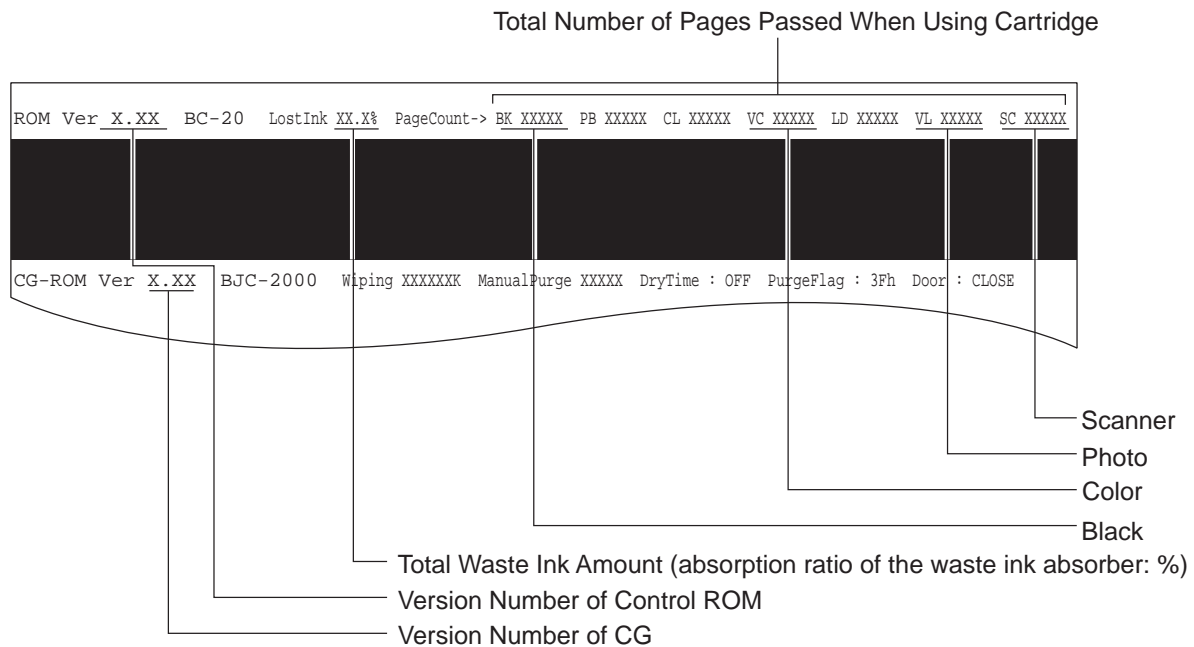

Figure 3-19 Service Test Print

The service test print is produced in the following procedure:

1. Without a cartridge installed, connect the plug of the AC adapter to the AC outlet while holding down the *RESET* button.
2. Release the *RESET* button. Press it down again within five seconds and release it.
3. Open the front cover and install the black BJ cartridge.
4. Press the *RESET* button twice and close the front cover. The printer starts the service test printing.

2.4 EEPROM Reset

The EEPROM records various settings, the data on the total number of sheets printed, and the total waste ink absorption amount for the color and black ink cartridges respectively. The total number of sheets printed and the total waste ink absorption amount can serve as a reference for how much the printer has been used.

The EEPROM must be reset when the logic board or the bottom cover is replaced.

See *Part 5: 4.3 Logic Board and Bottom Cover Replacement Cautions (page 5-5)*, for details.

2.4.1 EEPROM Reset

"Waste ink full" is detected with the total waste ink absorption amount recorded in the EEPROM. When the ink absorber is replaced, the data on the total waste ink absorption amount in the EEPROM must be reset. Furthermore, when the logic board is replaced, the new logic board's EEPROM must be reset and the waste ink absorber must be also replaced at the same time. To reset the EEPROM, follow the procedure below.

1. Without the cartridge installed, connect the plug of the AC adapter to the AC outlet while holding down the *RESET* button.
2. Release the *RESET* button. Press it down again within five seconds and release it.
3. Hold down the *RESET* button for two seconds or more and release it.
4. Set EEPROM by pressing the *RESET* button as shown in the table below.

TABLE 3-3 DEFAULT SETTING WHEN RESETTING THE EEPROM

Operation	Contents of setting
Hold down for two seconds or more.	EEPROM reset & destination setting (Other than Japan)
Press once.	Destination setting (Japan)
Press twice. (Second time: within one sec. of first time)	Destination setting (Others) (reference: Will not reset EEPROM)

5. To check this procedure, power off the printer first, then, after turning the printer on again, make a service test print. See *2.3.2 Service test print (page 3-18)*.



Be careful when performing the above operation as the EEPROM data cannot be recovered once it is reset.

2.4.2 Printing the EEPROM data

The following data recorded in the EEPROM can be printed on the service test print. See *2.3.2 Service test print (page 3-18)*.

- 1) Total number of sheets for black, color and photo ink cartridges and scanner cartridge, respectively.
- 2) Total waste ink absorption amount.



Resetting the EEPROM will permanently erase all data contained.

This page intentionally left blank

Part 4

TECHNICAL REFERENCE

Page	
4 - 1	1. OVERVIEW
4 - 1	1.1 Printer Diagram
4 - 2	1.2 Print Signal Flow
4 - 3	1.3 Print Drive
4 - 5	2. FIRMWARE
4 - 5	2.1 720 dpi Printing/Smoothing Feature
4 - 6	2.2 Printing Modes
4 - 8	2.3 Optimum Printing Direction Control
4 - 8	2.4 Ink Smear Control
4 - 8	2.5 Head Overheating Protection Control
4 - 9	3. PRINTER MECHANICAL SYSTEM
4 - 9	3.1 Overview
4 -10	3.2 BJ Cartridge
4 -17	3.3 Purge Unit
4 -19	3.4 Carriage
4 -22	3.5 Paper Feed
4 -24	4. PRINTER ELECTRICAL SYSTEM
4 -24	4.1 Overview
4 -25	4.2 Logic Section
4 -28	5. SENSOR FUNCTIONS
4 -28	5.1 Pick-up Roller Sensor
4 -28	5.2 Paper End Sensor
4 -28	5.3 Home Position Sensor (Purge Sensor)
4 -28	5.4 Temperature Sensor
4 -29	5.5 Head Temperature Sensor
4 -29	5.6 Waste Ink Amount Detection
4 -30	6. SCANNER CARTRIDGE
4 -30	6.1 Scanner Cartridge Overview
4 -31	6.2 Scanner Cartridge Structure
4 -33	6.3 Signal Contacts
4 -33	6.4 Scan Mode
4 -33	6.5 Calibration

1. OVERVIEW

1.1 Printer Diagram

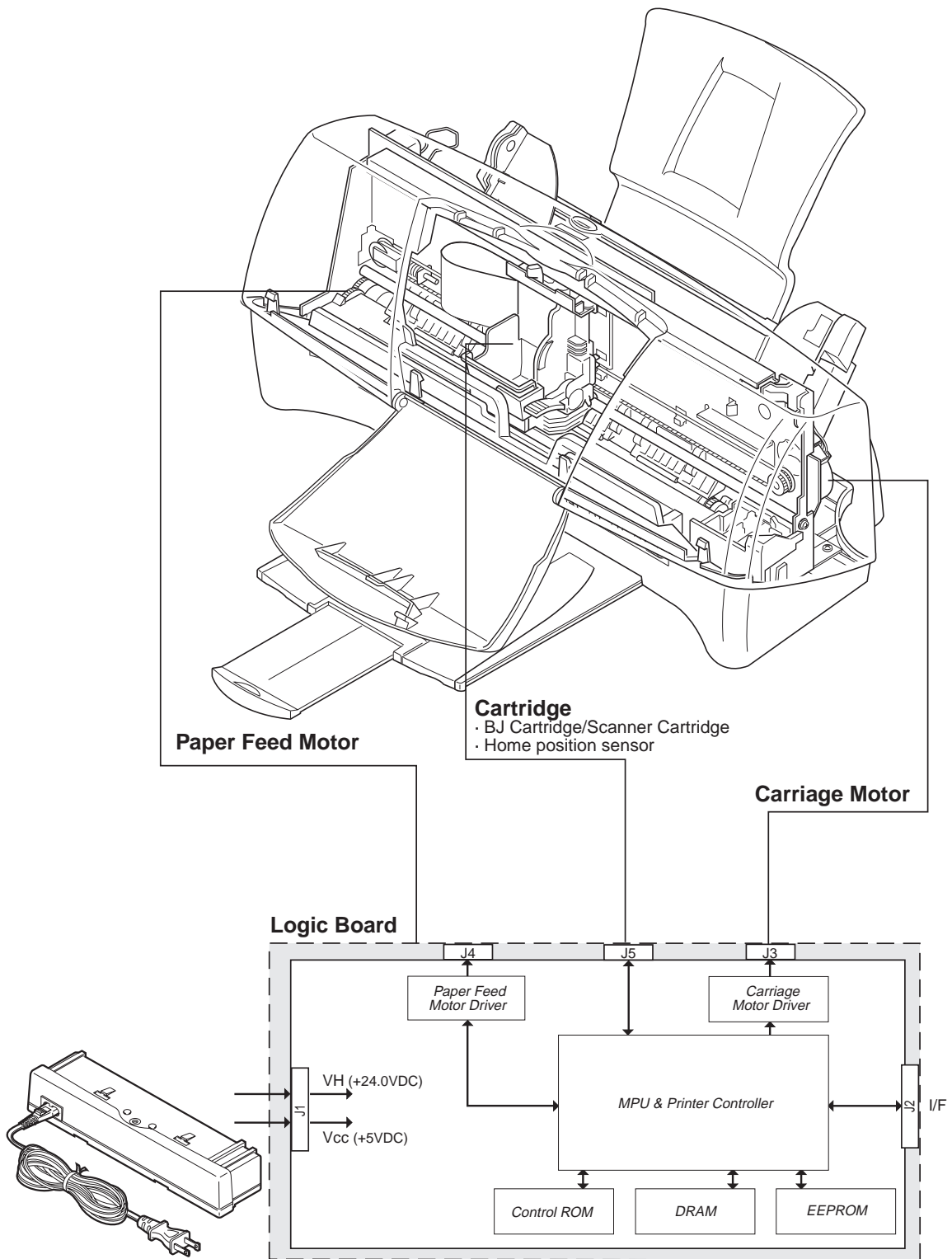

Figure 4-1 Printer Diagram

1.2 Print Signal Flow

The print signal flow from when the printer receives the print data to when printing is executed is described below.

- The printing information, including control signals output by the host computer, is loaded through the parallel interface into the MPU & printer controller on the logic board. The printing information is separated into control commands and print data based on the data stored in the control ROM. The control commands are processed in the MPU & printer controller. The print data is stored in the DRAM print buffer.
- The MPU & printer controller converts the print data into serial data as print drive signals and outputs the serial data to the bubble jet head. In the bubble jet head, the print data is converted from serial signals to parallel print data for each printed line. Printing is executed while the printer controller is controlled by the print control signals.
- The MPU & printer controller monitors the status of the bubble jet head and printer and uses the control ROM and motor drivers to manage all printing driver controls.

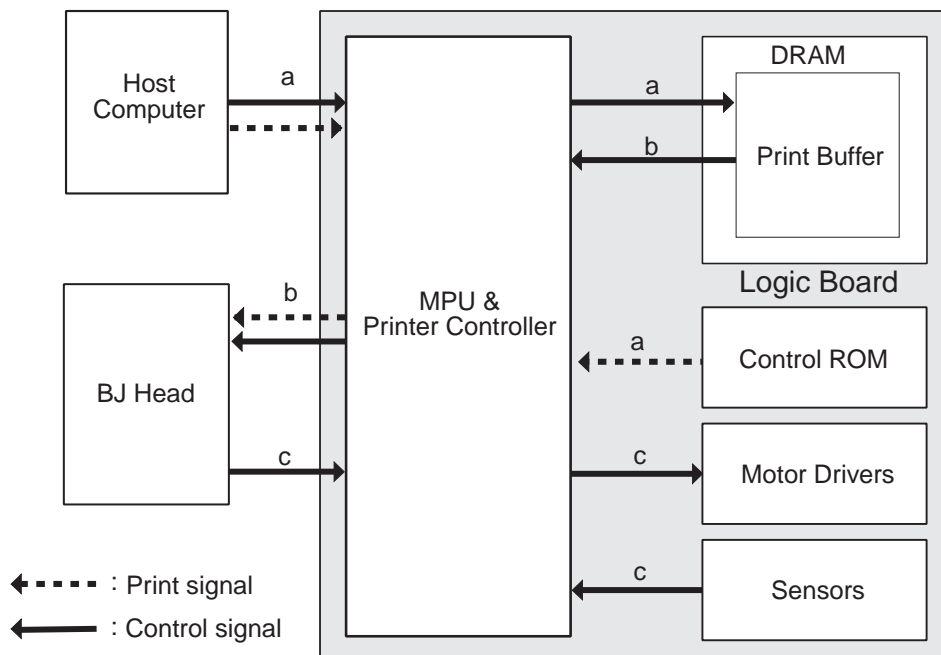

Figure 4-2 Printing Signal Flow

1.3 Print Drive

To eject ink from the head for printing, the printer outputs control signals from the printer controller to the BJ head.

The control signals consist of the drive control signal for ejecting ink from the head's nozzles and the temperature control signal for adjusting the head's temperature so that the amount of ink ejected is uniform.

To achieve optimum printing, both these control signals are optimized by the printer controller and sent from the carriage ribbon cable's signal contacts to the BJ head. The drive frequency varies depending on the printing mode and BJ cartridge type.

1.3.1 Printing drive control

a) Black BJ cartridge drive control

The black BJ cartridge drive control is executed by dividing the head's 128 nozzles into 8 blocks (16 nozzles each). These blocks are further divided into odd and even blocks (8 nozzles each). The odd blocks eject ink simultaneously and the even blocks do so as well. The control signals for the former are the block enable 1, 2, and 3 signals (BENB 1, 2, 3) and for the latter the signals are the even/odd enable signals (Even/odd ENB).

The heat enable 0 and 1 (HENB 0, 1), which are the heater drive control signals for ejecting the ink, are comprised of a pre-pulse and main pulse. To constantly achieve optimum ink ejection, the internal conditions such as the head's rank, printer temperature, and head temperature are monitored and the heater drive pulse width is varied before the pulse is output. Furthermore, the print drive signal from the printer controller is transferred to the BJ head's shift resistor according to the HLATCH timing. The printing drive signal (HDATA) is latched, and when the print control and heater drive control signals are output together, the heater for the applicable nozzles is driven and the ink is ejected.

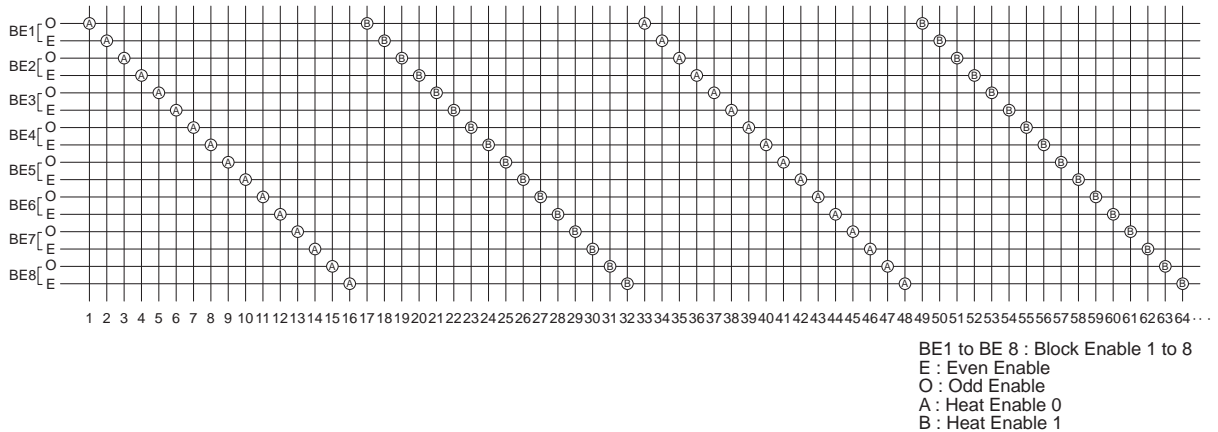

Figure 4-3 Printing Sequence (Black BJ Cartridge/HQ Mode)

b) Color BJ Cartridge (Multi-Drop) Drive Control

The multi-drop type color BJ cartridge's printhead has 136 nozzles and each nozzle has two heaters located one in front of the other. The printing operation using this multi-drop type color BJ cartridge is (dependent/influenced) by how these heaters are controlled.

The sequence of ink ejection is as follows. The 136 nozzles has 8 function blocks (16 nozzles/block) and each block is separated into two functional units. Hence, each functional unit has 8 nozzles. Ink is consecutively ejected from each unit.

Selection of the nozzles to be ejected is done by BLOCK ENABLE signals 1, 2 and 3 (BENB 1,2,3) and the EVEN/ODD ENABLE signal (Even/Odd ENB). HEAT ENABLE (HENB 0,1,2,3) is the heat drive control signal for ejecting ink.

The HEAT ENABLE signal controls ink ejection as follows:

- HENB 0: signals the nozzle (black) at the back
- HENB 1: signals the nozzle (black) at the front
- HENB 2: signals the nozzle (color) at the front
- HENB 3: signals the nozzle (color) at the back

The HEAT ENABLE signal is made up of the prepulse and the main pulse. To optimize ink ejection, the head rank, printer's inner temperature, and head temperature are constantly monitored. The ink is ejected by varying the HEAT ENABLE pulse width.

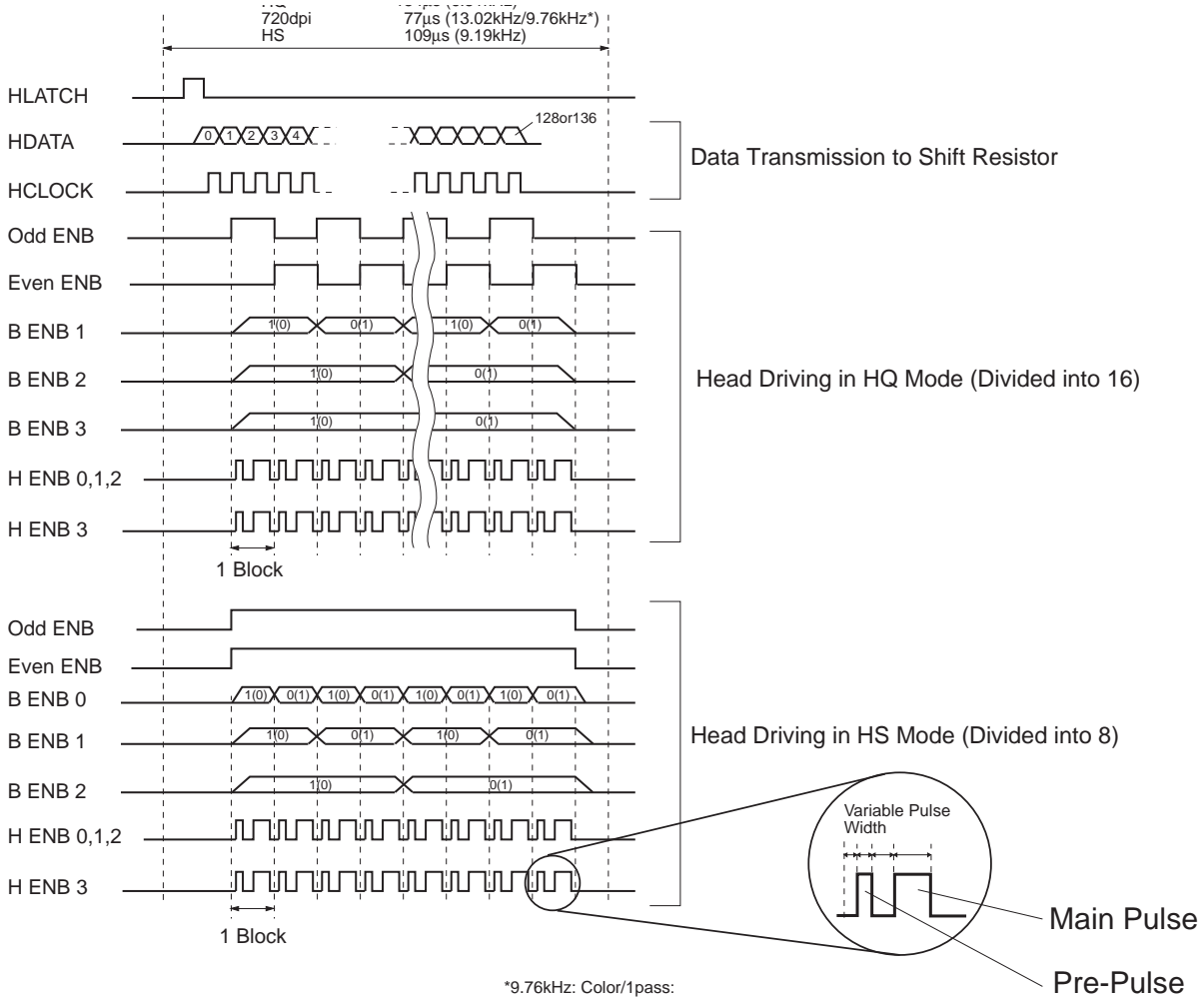

*9.76kHz: Color/1pass:

Figure 4-4 Printing Signals

2. FIRMWARE

2.1 720 dpi Printing Feature

2.1.1 Canon extended mode

In Canon extended mode, the printer driver creates 720 dpi data for the horizontal direction and sends it to the printer, allowing the printer to achieve high-quality printing.

With a black BJ cartridge installed, the printer driver smoothes the printed character's edges to 720 dpi along the horizontal direction. The 720 dpi data for the horizontal direction is sent to the printer and the edges are smoothed at a higher resolution.

When a color BJ cartridge is installed, a 360 dpi data is represented by a set of two dots printed simultaneously to obtain a 720 dpi resolution. The multi-value data of the pixels processed by the printer driver for color correction, etc., is assigned three values (no printing, single-dot printing, two-dot printing) for each pixel. In the case of two-dot printing, the second dot is printed in the 720 dpi position. As a result, this method enables the printer to achieve high degree gradation printing.

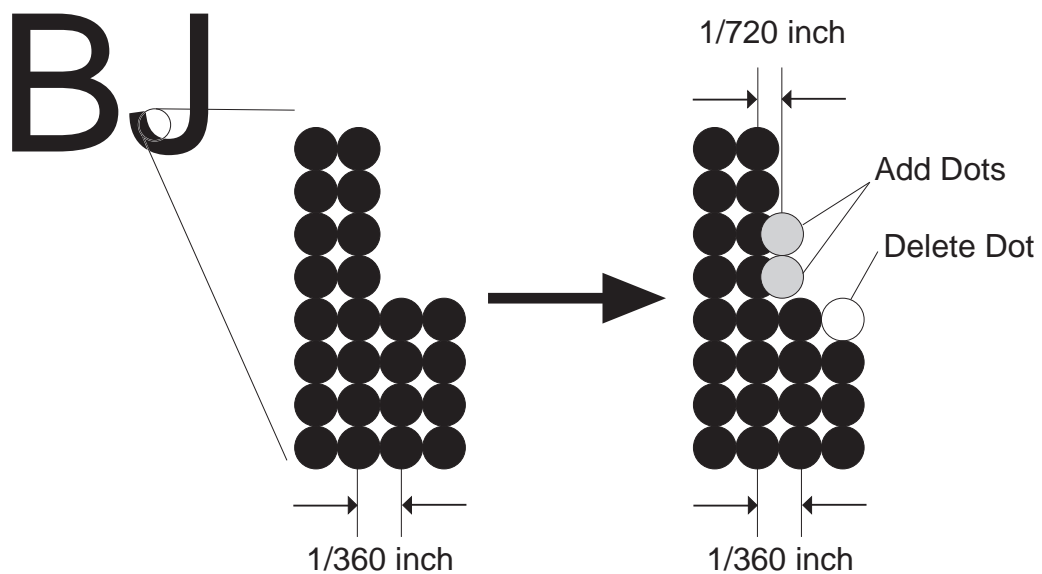

Figure 4-5 720 dpi Printing Feature

2.2 Printing Modes

2.2.1 Printing mode

Depending on the cartridge installed, the media, the printing mode, the resolution, the print data, etc., the printer varies the carriage movement, bubble jet head driving frequency, etc., to attain high-quality printing without any bleeding or shifting in the printout.

When the 720 dpi printing feature is used, the carriage feed pitch is set to 1/720 inch. Although, the bubble jet head drive frequency (ink ejection frequency) is increased, the carriage speed is slowed, so that the overall printing throughput decreases.

During color printing at a single pass, different colors printed at the same time overlap, often causing the colors to run. By printing with three passes, color bleeding is less prone to occur since the color printed immediately before is stable by the time the next color is printed over it.

When print data is processed internally by the printer, the data is recognized and the number of ink nozzles to be used by the black ink is changed automatically.

For color printing with Color-HQ2, at 720 dpi, processing is executed in such a way to prevent the color and black inks from running at their mutual borders and to prevent white mist.

This processing is executed as follows:

During internal processing by the printer, the borders where the color and black inks meet are identified. Cyan and black ink are mixed in the printed black portion to suit the state of the distance and density of the black and color dots.

The printing method for the respective printing modes are listed below.

2.2.2 Photo print mode

Photoprint mode can be used to obtain high level gradation print quality when using the Photo BJ cartridge. These cartridges contain a light density ink which achieves a high level of gradation by printing several times over the same dot.

The printer driver divides the pixel data into a maximum of 4-values (not printed, print 1 dot, print 2 dots and print 3 dots) enabling each pixel to be printed in up to 4 gradations. The printer therefore makes three passes using a maximum of 150% more ink than usual.

It is therefore necessary to use the exclusive print driver when printing with the Photo BJ cartridge.

The exclusive printer driver outputs multiple print data to the printer when photoprinting. If for some reason, a standard color BJ cartridge is installed and used for photoprinting, everything printed will be doubled in size in the carriage direction. On the other hand, if color printing is performed with a Photo BJ cartridge, not only will printed images appear light, the user will be notified of a mis-match as images will be printed in half their normal size.

2.2.3 Multi-Drop print mode

When a color cartridge or a photo color cartridge using drop modulation technology is installed, the Canon original driver must be used. By selecting a drop modulation mode such as fine or photo mode, large and small ink droplets can be printed. When large and small dots are used efficiently, the granularity of the light areas can be improved.

To avoid slowdown, large and small droplet printing is not used for HQ and HS modes since these modes do not give a gradation.

TABLE 4-1 PRINTING MODES AND HEATING METHODS**With a Black BJ Cartridge**

Printing Mode	Carriage Movement	Number of Nozzles	Heat Frequency [*1]
Bk-HQ	1 pass	128 nozzles	6.51KHz [6.51KHz (13.02KHz)]
Bk-Fine1	4 passes	32 nozzles	6.51KHz [6.51KHz (13.02KHz)]
Bk-Fine2	4 passes	32 nozzles	6.51KHz [6.51KHz (13.02KHz)]
Bk-Fine-Cloth	4 passes	32 nozzles	6.51KHz [6.51KHz (13.02KHz)]
Color-HQ1	1 pass	128 nozzles	6.51KHz [6.51KHz (13.02KHz)]
Color-HQ2	1 pass	128 nozzles	6.51KHz [6.51KHz (13.02KHz)]
Color-Fine1	4 passes	32 nozzles	6.51KHz [6.51KHz (13.02KHz)]
Color-Fine2	4 passes	32 nozzles	6.51KHz [6.51KHz (13.02KHz)]
Color-HS	1 pass	128 nozzles	9.19KHz

With a Color BJ Cartridge (Multi-Drop)

Printing Mode	Carriage Movement	Number of Nozzles	Heat Frequency [*1]
Bk-HQ	1 pass	64 nozzles for black	6.51KHz [6.51KHz (13.02KHz)]
Bk-Fine1	4 passes	16 nozzles for black	6.51KHz [6.51KHz (13.02KHz)]
Bk-Fine2	4 passes	16 nozzles for black	6.51KHz [6.51KHz (13.02KHz)]
Bk-DFine1	4 passes	16 nozzles for black	6.51KHz [6.51KHz (13.02KHz)]
Bk-DFine2	4 passes	16 nozzles for black	6.51KHz [6.51KHz (13.02KHz)]
Bk-HS	1 pass	64 nozzles for black	9.19KHz
Color-HQ1	1 pass	Switches automatically between 24 and 64 nozzles	6.51KHz [4.88KHz (9.76KHz)]
Color-HQ2	1 pass	Switches automatically between 24, and 64 nozzles*2	6.51KHz [4.88KHz (9.76KHz)]
Color-Fine1	3 passes	8 nozzles	6.51KHz [6.51KHz (13.02KHz)]
Color-Fine2	3 passes	8 nozzles	6.51KHz [6.51KHz (13.02KHz)]
Color-DFine1	3 passes	8 nozzles	6.51KHz [6.51KHz (13.02KHz)]
Color-DFine2	3 passes	8 nozzles	6.51KHz [6.51KHz (13.02KHz)]
Color-HS	1 pass	Switches automatically between 24 and 64 nozzles	9.19KHz

With a Photo BJ Cartridge (Multi-Drop)

Printing Mode	Carriage Movement	Number of Nozzles	Heat Frequency [*1]
Bk-HQ	1 pass	64 nozzles for black	6.51KHz [6.51KHz (13.02KHz)]
Bk-Fine1	4 passes	16 nozzles for black	6.51KHz [5.21KHz (10.42KHz)]
Bk-Fine2	4 passes	16 nozzles for black	6.51KHz [5.21KHz (10.42KHz)]
Bk-DFine1	4 passes	16 nozzles for black	6.51KHz [5.21KHz (10.42KHz)]
Bk-DFine2	4 passes	16 nozzles for black	6.51KHz [5.21KHz (10.42KHz)]
Bk-HS	1 pass	64 nozzles for black	9.19KHz
Color-HQ1	1 pass	Switches automatically between 24 and 64 nozzles	6.51KHz [4.88KHz (9.76KHz)]
Color-HQ2	1 pass	Switches automatically between 24, and 64 nozzles*2	6.51KHz [4.88KHz (9.76KHz)]
Color-Fine1	3 passes	8 nozzles	6.51KHz [5.21KHz (10.42KHz)]
Color-Fine2	3 passes	8 nozzles	6.51KHz [5.21KHz (10.42KHz)]
Color-DFine1	3 passes	8 nozzles	6.51KHz [5.21KHz (10.42KHz)]
Color-DFine2	3 passes	8 nozzles	6.51KHz [5.21KHz (10.42KHz)]
Color-HS	1 pass	Switches automatically between 24 and 64 nozzles	9.19KHz

*1 []: Carriage speed (heat frequency) for 720 dpi printing.

*2 When the print resolution is 720 dpi, processing to prevent colors running at the borders is not executed.

2.3 Optimum Printing Direction Control

To prevent vertical misalignment of printed characters, etc., when printing data is printed continuously in the direction of the paper feeding direction, printing is executed with the carriage moving in only one direction.

However, when printing in the paper feed direction is not continuous, since vertical misalignment is not so noticeable, the printing direction is alternated so that printing is also executed from the opposite carriage direction. This improves the throughput.

If four or more successive null rasters are detected in the lower (in the direction of paper ejection) 64 nozzles (24 nozzles with a color BJ cartridge) for the print data in the printer buffer during single-pass printing, printing is executed up to the null raster.

From the null raster onward, printing is executed from the opposite carriage direction.

From the next raster onward, printing is executed from the same carriage direction until the direction changes again.

2.4 Ink Smear Control

Immediately after the printed sheet is ejected from the printer, the ink dries naturally on the paper output tray. If the next printed sheet is ejected before the ink on the preceding sheet has enough time to dry on the paper output tray, the ink may be smeared when the next sheet slides over the preceding one. To prevent this, a wait period is applied during printing so that sheet ejection is delayed, giving more time for the ink on the preceding sheet to dry.

When a black BJ cartridge is used (whose printing speed is faster), and high duty printing is completed, the printer automatically detects the high duty printing position and the time elapsed from the start of printing.

There is no need to execute ink smear control when a color BJ cartridge is used.

2.5 Head Overheating Protection Control

If the ink has run out and the printing operation is continued, the bubble jet head can get extremely hot. If the head temperature sensor in the bubble jet head detects a temperature above the temperature limit, head overheating control is executed.

Protection level 1:

This level prevents the user from touching the bubble jet head's hot aluminum plate when the bubble jet head is replaced. For this purpose, when the front cover is opened, the carriage will not move to the cartridge replacement position. Close the front cover, leave the printer inactive for a few minutes to allow it to cool, and then open the front cover again to perform the required operation.

Protection level 2:

If a high temperature is still detected, the carriage is returned to the home position for 3.5 seconds to bring down the temperature. After the resting period, printing will resume. This continues for over 20 seconds' to lower the head's temperature.

Protection level 3:

If the temperature continues to increase, a head temperature error occurs. This stops the printing operation.

3. PRINTER MECHANICAL SYSTEM

3.1 Overview

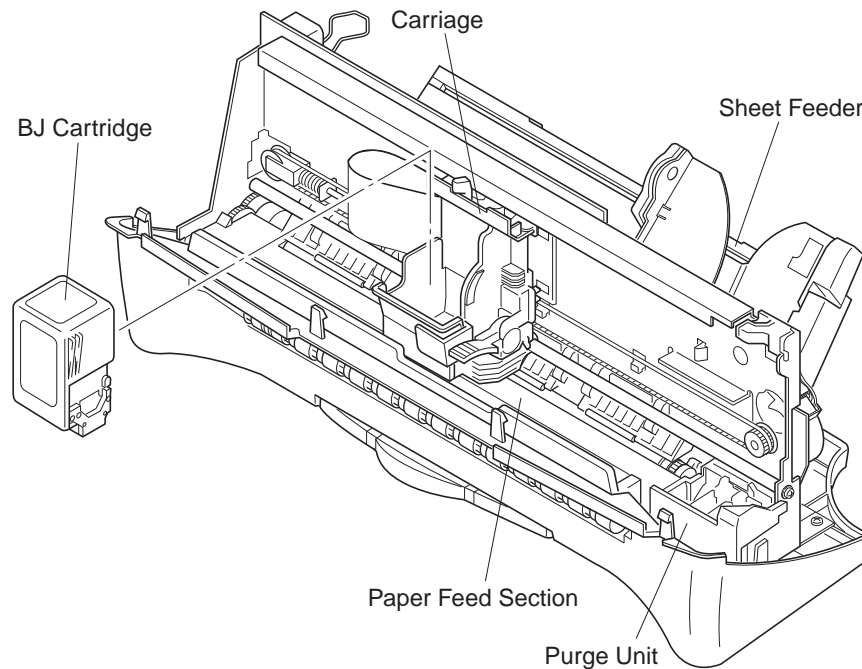

Figure 4-6 Printer's Mechanical Configuration

This section explains the printer's mechanical components.

3.1.1 Mechanical components

1) BJ cartridge

The printer comes with three types of BJ cartridges: black, color, and photo. The user installs the black or color BJ cartridge according to the required application. The black BJ cartridge has an integrated head while the color BJ cartridge has replaceable ink cartridges.

2) Purge unit

Driven by the carriage motor, the purge unit helps to maintain high-quality printing by capping and wiping the BJ cartridge's bubble jet face. It ensures that the ink in the nozzles is ejected easily.

When the printer is not in use, the purge unit caps the BJ cartridge's nozzles for protection.

3) Carriage

Driven by the carriage motor, the carriage moves horizontally across the paper. Through the carriage ribbon cable, the printing signals from the logic board are transmitted to the BJ cartridge in the carriage.

By controlling the purge unit's slide lock pin, the carriage controls the engagement of the paper feed motor's drive power between the paper feed/purge unit and the sheet feeder.

4) Paper feed mechanism and sheet feeder

The built-in sheet feeder is driven by the paper feed motor. Plain paper as well as coated paper, transparencies, back print film, envelopes, etc., can be loaded and fed automatically into the paper feed mechanism.

Driven by the paper feed motor, the paper feed mechanism rotates the feed rollers to feed the paper vertically.

When printing transparencies and back print film, remove each sheet from the paper output tray immediately after it is printed. This is to allow enough time for the ink to dry.

The paper ejection operation of this printer is performed using the *RESET* button.

3.2 BJ Cartridge

3.2.1 Black BJ cartridge structure

The black BJ cartridge consists of a 128 nozzle print head and integrated ink cartridge.

1) Cartridge cover

The plastic cover is attached to the cartridge body to prevent the ink from leaking inside the cartridge.

As the ink is consumed, the pressure inside the cartridge decreases in relation to the atmospheric pressure. This makes it harder for the ink to be supplied to the head.

To prevent this, the cartridge cover is provided with a pressure adjusting hole for maintaining constant pressure inside the cartridge body.

2) Ink sponge

The sponge is soaked with black ink. It is compressed and stored in the cartridge body.

3) Cartridge body

The plastic case connects the ink sponge with the bubble jet head unit via the ink filter.

4) Bubble jet head unit

Ink is ejected through the 128 bubble jet nozzles, according to the print signals received through the signal contact.

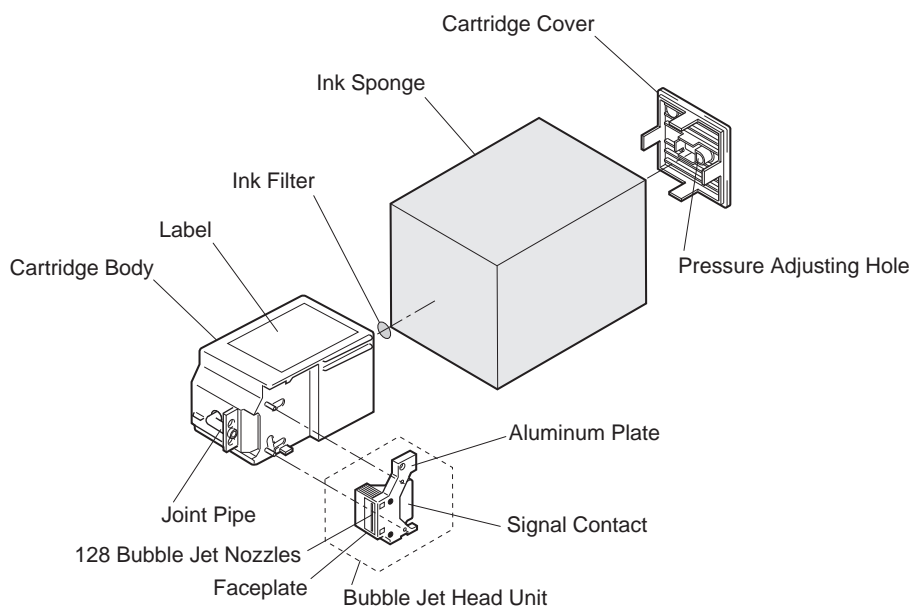

Figure 4-7 Black BJ Cartridge Structure

3.2.2 Color BJ cartridge structure

The color BJ cartridge has a print head equipped with 136 nozzles through which the four ink colors are ejected (24 nozzles each for yellow, magenta, and cyan; 64 nozzles for black). The ink cartridges (one for black and one for the other three colors) are removable and replaceable.

1) Pressure adjusting plates

As the ink is consumed, the pressure inside the cartridge decreases in relation to the atmospheric pressure. This makes it harder for the ink to be supplied to the head. To prevent this, the ink cartridge is provided with a pressure adjusting hole for maintaining constant pressure inside the cartridge body.

2) Ink sponges

Each ink color (black, cyan, yellow, magenta) is soaked in its own respective sponge. The cyan, yellow, and magenta ink sponges are compressed and stored in the same color ink cartridge body.

3) Ink suppliers

These supply the ink from the ink sponges to the cartridge's joints at a constant pressure.

4) Ink cartridge body

This is a plastic case which links the ink sponge with the color BJ cartridge via the ink suppliers.

5) Rubber sheets

This sheet seals the joints between the ink cartridge and BJ cartridge.

6) Ink passage section

This is a passage through which the ink flows from the ink cartridge to the head unit.

7) Bubble jet head unit

From the ink cartridges, the four ink colors are supplied separately to the 136 bubble jet nozzles. Ink for the four colors is ejected through the 136 bubble jet nozzles, according to the print signals received through the signal contacts.

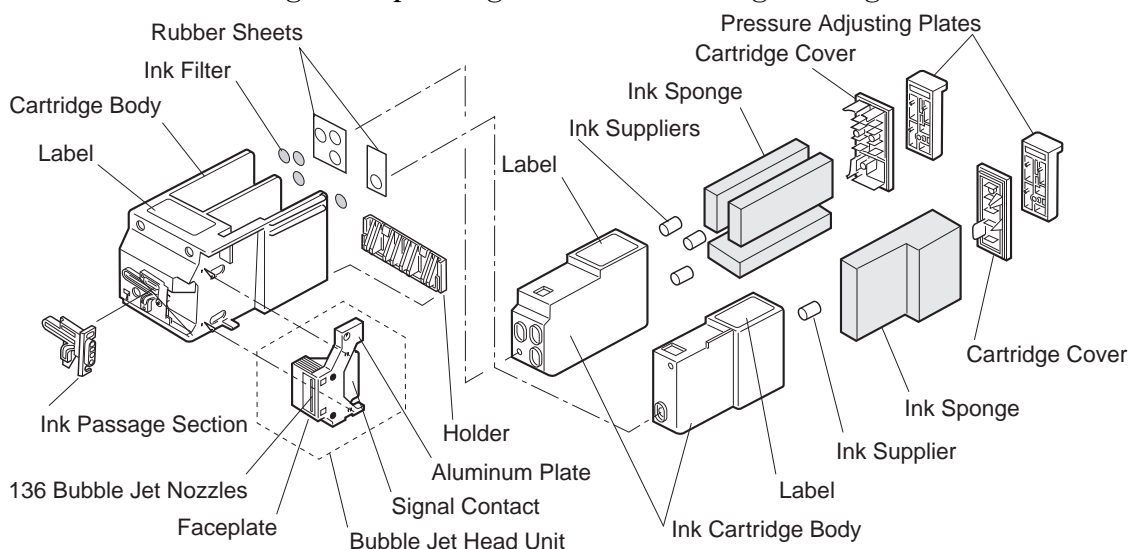

Figure 4-8 Color BJ Cartridge Structure

3.2.3 Photo BJ cartridge structure

The photo BJ cartridge has a print head equipped with 136 nozzles through which the four ink colors are ejected (24 nozzles each for yellow, magenta, and cyan; 64 nozzles for black).

1) Pressure adjusting plate

As the ink is consumed, the pressure inside the cartridge decreases in relation to the atmospheric pressure. This makes it harder for the ink to be supplied to the head. To prevent this, the ink cartridge is provided with a pressure adjusting hole for maintaining constant pressure inside the cartridge body.

2) Ink sponges

Each ink color (black, cyan, yellow, magenta) is soaked in its own respective sponge. The cyan, yellow, and magenta ink sponges are compressed and stored in the cartridge body.

3) Ink passage section

This is a passage through which the ink flows from the ink cartridge to the head unit.

4) Bubble jet head unit

From the ink cartridges, the four ink colors are supplied separately to the 136 bubble jet nozzles. Ink for the four colors is ejected through the 136 bubble jet nozzles, according to the print signals received through the signal contacts.

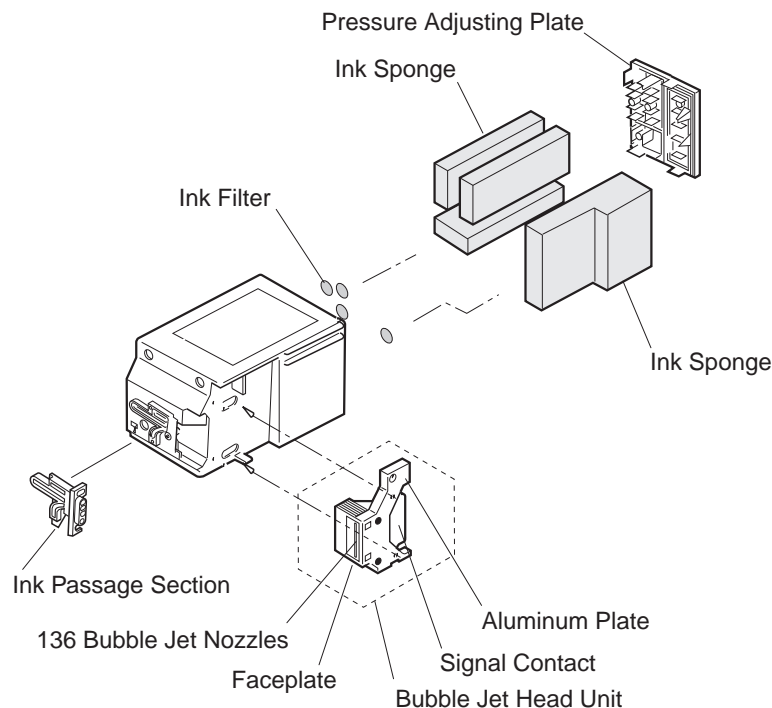

Figure 4-9 Photo BJ Cartridge Structure

3.2.4 Bubble head unit structure

1) Bubble jet nozzles

The ink held by the sponge goes through a mesh-type ink filter and flows to the bubble jet nozzles through the joint pipe.

When the head-drive current is supplied to the heater board, an ink bubble is produced. Eventually, only one ink bubble is formed. The head-drive current is turned off before the ink droplet leaves the nozzle. The bubbling however continues with the residual heat and the ink droplets are ejected from the nozzles.

After an ink droplet is ejected, the nozzle is replenished with more ink from the ink sponge.



The print head's heater board uses semiconductor technology with the heater and circuitry built on a silicon plate.

This silicon plate, which contains electrical circuitry, is attached to an aluminum base. The plastic cover, which is shaped to fit the nozzles, is also attached.

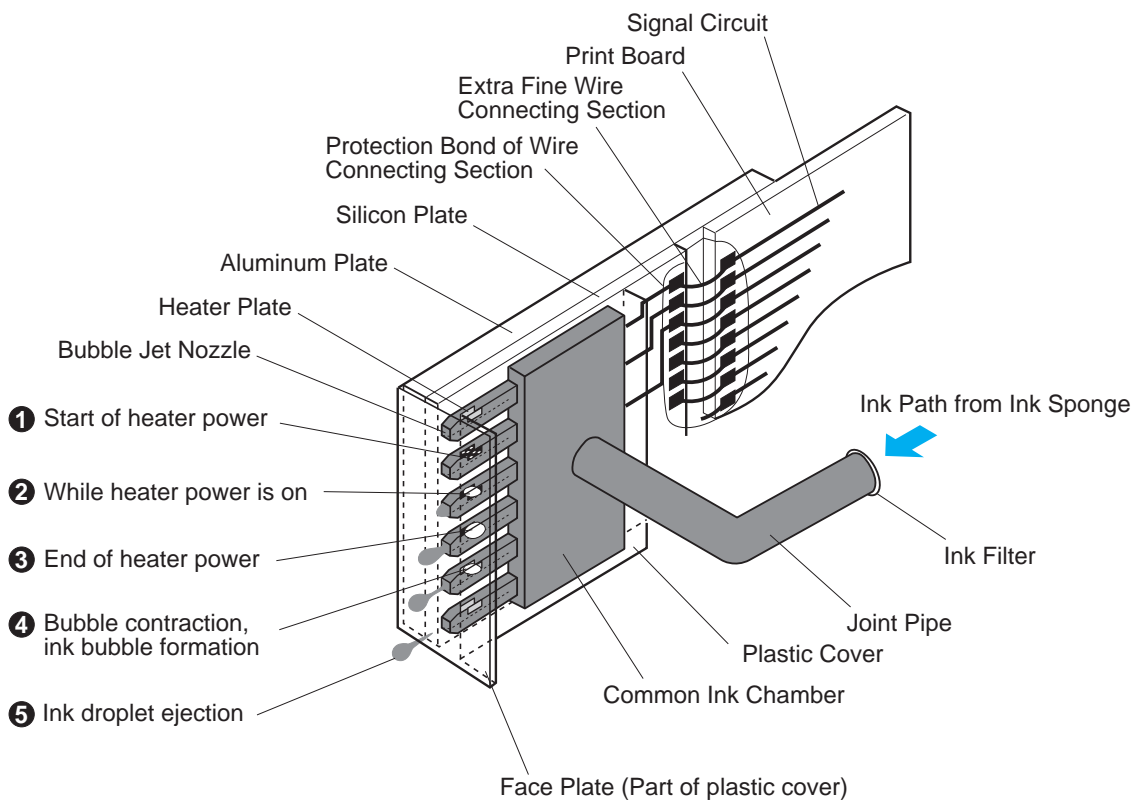

Figure 4-10 Bubble Jet Nozzles (Partial View)

2) Nozzle arrangement

The bubble jet nozzles are arranged 1/360 inch apart in a vertical array. The black BJ cartridge has 128 nozzles. On the color BJ cartridge, the first 24 nozzles are for yellow ink, the second 24 nozzles are for magenta ink, the third 24 nozzles are for cyan ink, and the remaining 64 nozzles are for black. The color BJ cartridge has a total of 136 nozzles.

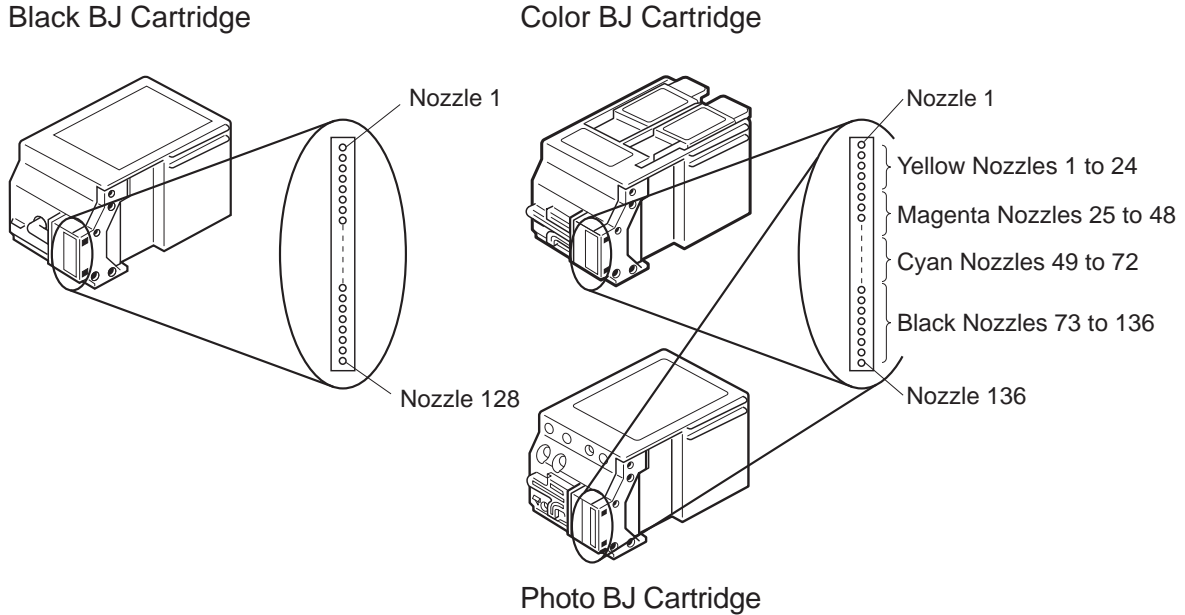

Figure 4-11 Nozzle Arrangement

3) Signal connection point (contact pad)

See Part 5: 6.3 BJ Cartridge & Scanner Cartridge (page 5-26).

4) Circuit diagram

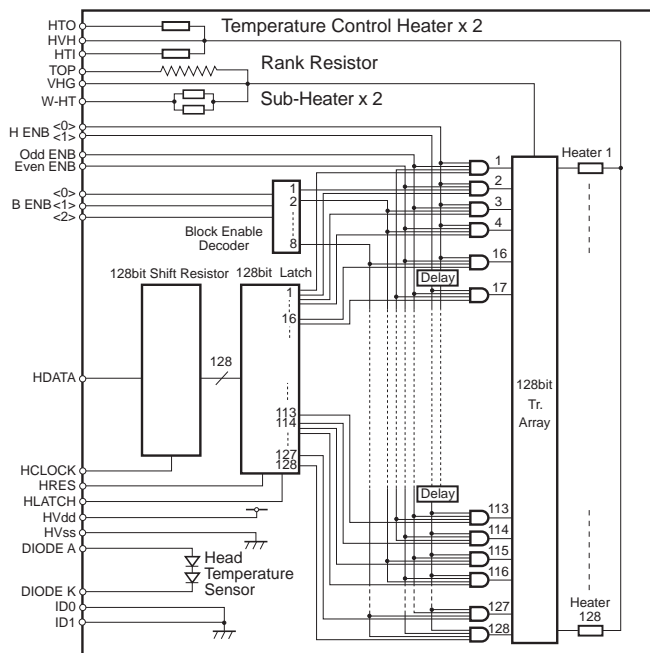
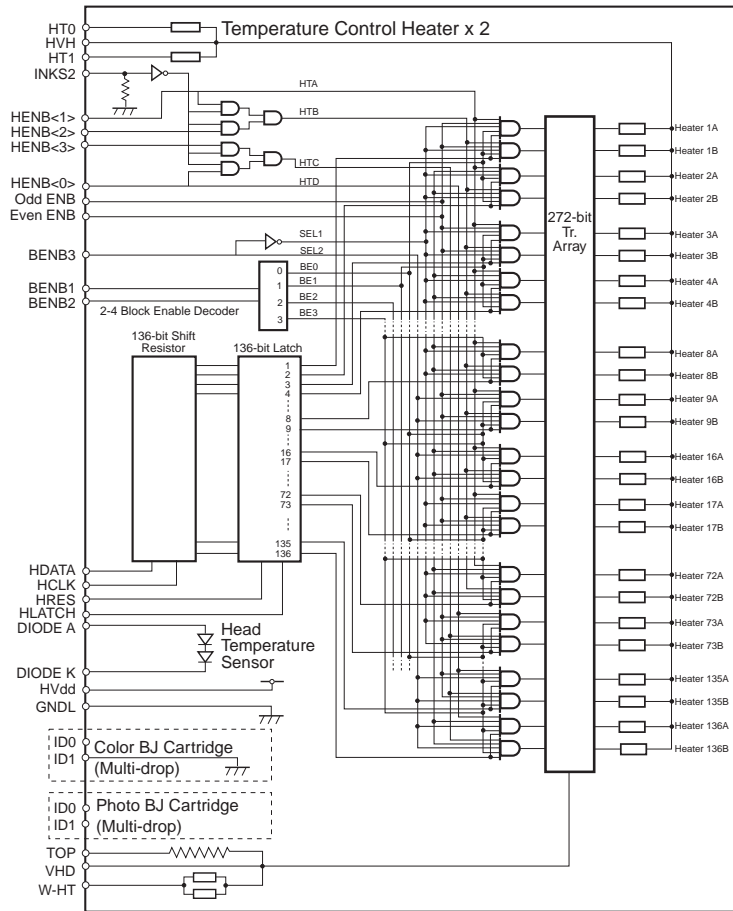

Figure 4-12 Black BJ Cartridge Block Diagram



Color BJ cartridge (Multi-Drop) and photo BJ cartridge (Multi-Drop) have the same circuit configuration except for the ID1 connection.

Figure 4-13 Color (Multi-Drop)/ Photo (Multi-Drop) BJ Cartridge Block Diagram

- **128/136 bit shift resistor**
Stores the print data (HDATA) transferred from the control board at HCLOCK's timing.
- **128/136 bit latch**
Latches the print data (HDATA) converted by the 128/136 bit shift resistor.
- **Block enable decoder**
After the BENB (Block enable) 1, 2, and 3 code signals are input, the specified heat timing signal is output. The heat timing signal is divided into eighths.
- **Heater (1 to 128 and 1 to 136)**
The heater generates the bubbles required for the nozzles to eject the ink. The heater heats the bubble jet nozzles. Heating is executed with the timing signal produced by the block enable decoder and the even nozzle heat enable (EvenENB), odd nozzle heat enable (OddENB), and heat enable (HENB0 to 3) signals.
- **Sub-Heater**
This heater maintains the optimum conditions in the nozzle for ink ejection.
- **Temperature control heater**
This heater controls the head temperature to stabilize the ink ejection amount.

- **Rank resistor**

To execute optimum heat control of each BJ cartridge, production-related deviation in heater characteristics is classified into 13 types which are identified by changing the rank resistance. From the MPU & Printer Controller's analog port, the MPU detects the different rank resistances as voltage values and converts them from analog to digital for detection. The heater's characteristics are thereby recognized.

- **Head temperature sensor**

Temperature changes in the nozzle's heater are detected by the diode to prevent the bubble jet head from overheating.

- **Cartridge ID**

The BJ cartridge type (color or black) is recognized, through combinations of ID0, ID1, and INKS2.

5) Ink cartridge detection and identification feature

This printer detects the presence of a BJ cartridge by the two resistance values of TOP (pin 9) and DIODEA (pin 10) of the cartridge signal contacts. When the resistance value of TOP is 750 Ω or less and that of DIODEA is not zero Ω , the printer decides that the cartridge is installed. When the resistance values of these pins do not comply with the above values, the printer decides that a cartridge is not installed.

When the printer detects the BJ cartridge, the installed BJ cartridge is identified (black, color, or photo BJ cartridge) based on ID0 (pin 11), ID1 (pin 12), and INKS2 (pin 13) of the cartridge signal contacts.

If the printer is turned on without the BJ cartridge (for example, if the user turns on the printer immediately after unpacking the printer), the carriage automatically moves to the cartridge replacement position regardless of its previous position. Also, if the printer is on and the cartridge is removed without replacement, a BJ cartridge not installed error will occur.

TABLE 4-2 HEAD INSTALLATION STATUS AND SIGNAL DETECTION

	ID0	ID1	INKS2	TOP
Black BJ cartridge installed	Low	Low	High	Min. 60
Photo BJ cartridge (Multi-Drop) installed	Low	High	Low	
Color BJ cartridge (Multi-Drop) installed	High	Low	Low	
Color BJ cartridge installed (reference)	High	Low	High	
Photo BJ cartridge installed (reference)	High	High	High	
Scanner cartridge installed	-	-	(High)	Under 60

High: Signal detected

Low: No signal detection (by printer)

3.3 Purge Unit

3.3.1 Purge unit functions

1) Capping function

The purge unit's cap is pressed against the face of the print head to prevent the ink from drying out or leaking.

If print data is not received for over 60 seconds during a printing operation, the purge unit wipes the print head face. If print data is still not received for a further 60 seconds, the purge unit caps the print head.

Other than during a printing operation, if print data is not received after a certain period of time (varies between 5 to 20 seconds) the purge unit caps the print head.

2) Cleaning function

To maintain high print quality, the purge unit cleans the print head at the following times:

- After the AC power cord is connected.
- After the BJ cartridge is replaced.
- After the ink cartridge has been replaced.
- When printing starts after more than 72 hours have passed since the last cleaning (if a color BJ cartridge is installed, after more than 24 hours have passed for the first-time cleaning only).
- When the printed dot count exceeds the specified amount.
- When the color BJ cartridge is left at the cartridge replacement position for over 10 minutes.
- When cleaning is executed by button operation.

The cleaning operation includes the wiping of paper bits and ink residue adhering to the print head's face plate. It also sucks out ink from the print head to refresh the inside of the nozzles with fresh ink.

TABLE 4-3 INK CONSUMPTION DURING CLEANING (AS A STANDARD)

With a Black BJ Cartridge	Approximate Ink Consumption
During black BJ head replacement	0.15g
After AC power cord connection	0.15g
During black BJ cartridge replacement	0.15g
When printing starts after more than 72 hours since the last cleaning	0.15g
When dot count exceeds the specified count	0.15g
Button pressed for cleaning	0.15g
With a Color BJ Cartridge/ Photo BJ Cartridge	Approximate Ink Consumption
During color BJ head replacement	0.3g
After AC power cord connection	0.3g
When printing starts after more than 72 hours since the last cleaning (also after the first 24 hours as for the initial cleaning)	0.3g
During ink cartridge replacement	0.6g
When left at cartridge replacement position for over 10 minutes	0.6g
When the dot count exceeds the specified count	0.6g
Button pressed for cleaning	0.3g

3.3.2 Purge unit structure

1) Purge drive gear

Through a transmission gear, the purge drive gear is driven by the feed roller which is driven by the paper feed motor. The purge drive gear in turn drives the cam which controls the pump's operation.

The cam's position is detected by the home position sensor via the sensor arm.

2) Wiper unit

When the carriage moves from left to right, the wiper retracts so that it does not touch the head. However, when the carriage moves from right to left, the wiper wipes ink from the BJ cartridge's face plate at the following times:

Once every 60 seconds (or when the specified dot count is reached) during printing, when the paper pick-up operation ends, when the recovery operation ends, and when the cap is opened or closed.

3) Capping unit

The capping unit has a rubber cap. When the carriage moves to the home position, the cap is pressed against the print head's face plate.

Also, since the cap is connected to a pump, the cap sucks ink from the BJ cartridge during the cleaning operation. The ink which has been sucked out is sent to the base cover unit's waste ink absorber.

4) Maintenance jet receiving section

The maintenance jet receiving section takes in ink (for test ejection to maintain the nozzles' working condition) ejected from the BJ cartridge. The ink is received, and when a gear is rotated, the ink is sent to the waste ink absorber below.

5) Slide lock pin

The slide lock pin moves the cap when the carriage moves from left to right and reaches the capping position after moving from left to right. Capping is executed while the slide arm is unlocked.

When the slide arm is unlocked, the rotation of the feed roller is transmitted to the purge drive gear and sheet feeder.

6) Ink shield

The ink shield stops ink splattering when the wiper unit wipes off ink.

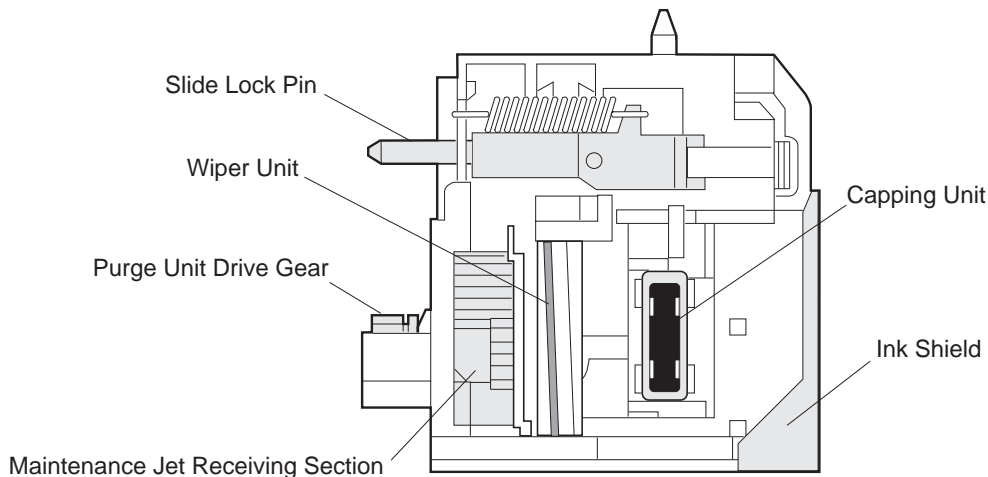

Figure 4-14 Purge Unit

3.4 Carriage

3.4.1 Carriage functions

1) Print head installation

BJ cartridges are attached mechanically and connected with electronic circuitry to the carriage.

2) Carriage driving

Driven by the carriage motor and carriage belt, the carriage moves across the paper horizontally.

3) Paper thickness adjustment

The paper thickness lever on top of the carriage, adjusts the gap between the paper and print head.

4) Paper feed motor driver

When the carriage moves to the cleaning position at the right end of the platen the slide arm is unlocked. The paper feed motor's drive power, normally used for paper feeding during printing, can be diverted to drive the purge unit and sheet feeder.

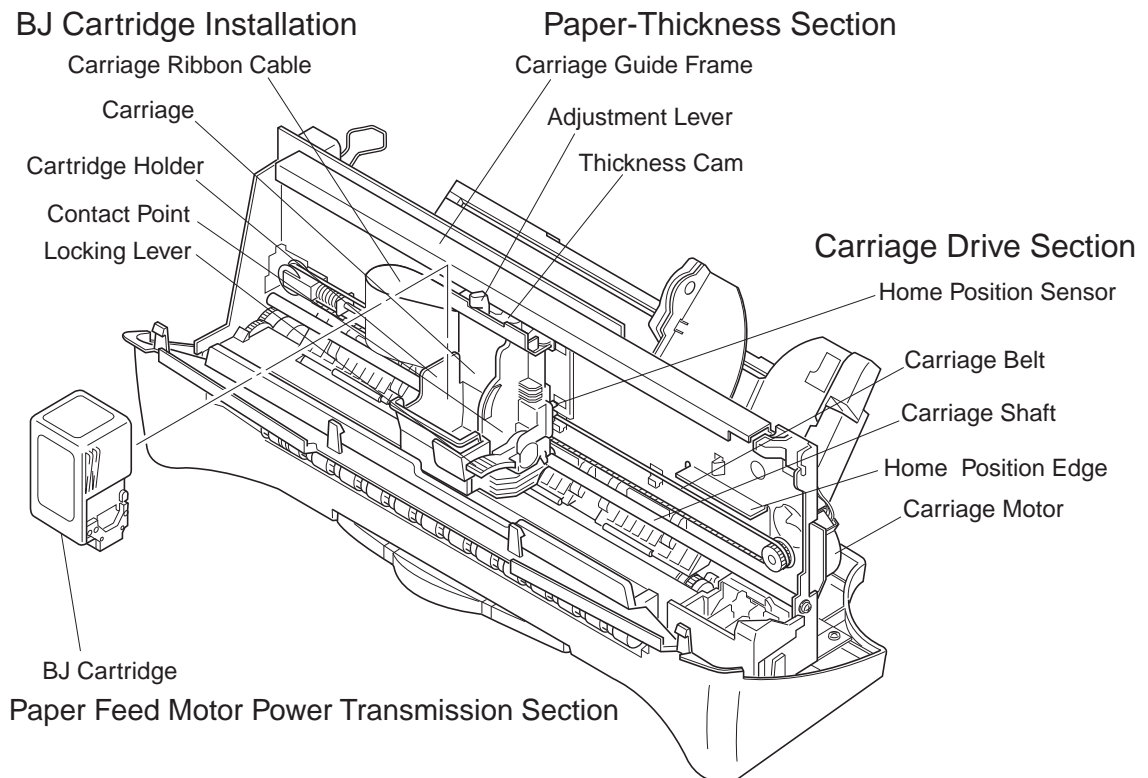

Figure 4-15 Carriage

3.4.2 Carriage structure

1) BJ cartridge attachment section

The cartridge holder moves with the locking lever which secures the BJ cartridge into the carriage.

When a BJ cartridge is secured into the carriage, the ribbon cable signal contacts are pressed against the bubble jet head signal contacts, enabling signals to be transmitted from the logic board.

2) Carriage driver

The stepping-type carriage motor drives the carriage horizontally across the paper with the carriage belt. After the photo interrupter's home position sensor behind the carriage detects the home position edge as the initial position, the carriage is controlled by the stepping pulse sent to the carriage motor.

The carriage motor is driven by a one to two-phase exciter at a fixed current.

A mechanical shift occurs during the bi-directional non-continuous printing in the paper feed direction. After the bi-directional carriage shift for each mode, the slightly-off timing of the detected home position edge is adjusted automatically by delaying the ejection of ink. The slightly-off timing of the detected home position edge is adjusted with software and thereby corrected automatically. During the initial operation, HQ mode is corrected. For the other modes, the misalignment is measured and corrected before printing starts.

3) Paper thickness setting

If envelopes or thick paper is fed for printing, they will rub against the head face causing possible damage and paper contamination. This can be prevented by using the proper paper thickness setting.

The gap between the head and paper must be set to the optimum setting (one of two settings) to match the thickness of paper being fed. This gap is adjusted by changing the angle of the carriage guide frame and the carriage attachment angle. The gap between the platen and head thereby changes.

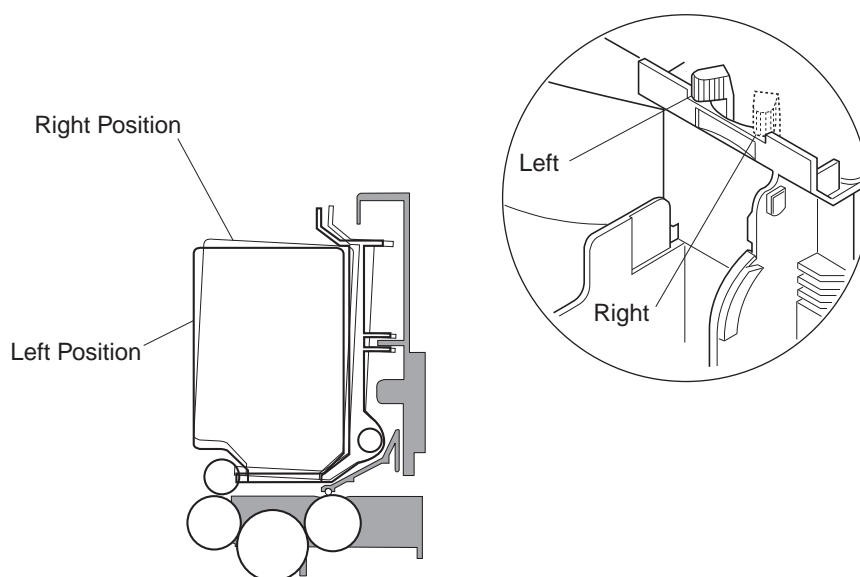

Figure 4-16 Paper Thickness Adjustment

4) Switching the paper feed motor drive transmission

The paper feed motor drives either the paper feed, purge unit, or cut sheet feeder according to the position of the carriage. When the carriage is not at the right end, the slide arm is locked by the purge unit's slide lock pin. In this condition, paper feed is driven by the feed roller. When the carriage is at the capping position, the slide arm is unlocked and the paper feed motor drives the purge unit and sheet feeder.

When the slide arm is unlocked and the feed roller is rotated in the feeding direction, the slide arm rotates until it reaches the sheet feeder gear to drive the gear.

When the slide arm is unlocked and the feed roller is rotated in the opposite direction of the feeding direction, the slide arm rotates until it reaches the purge drive gear to drive the gear.

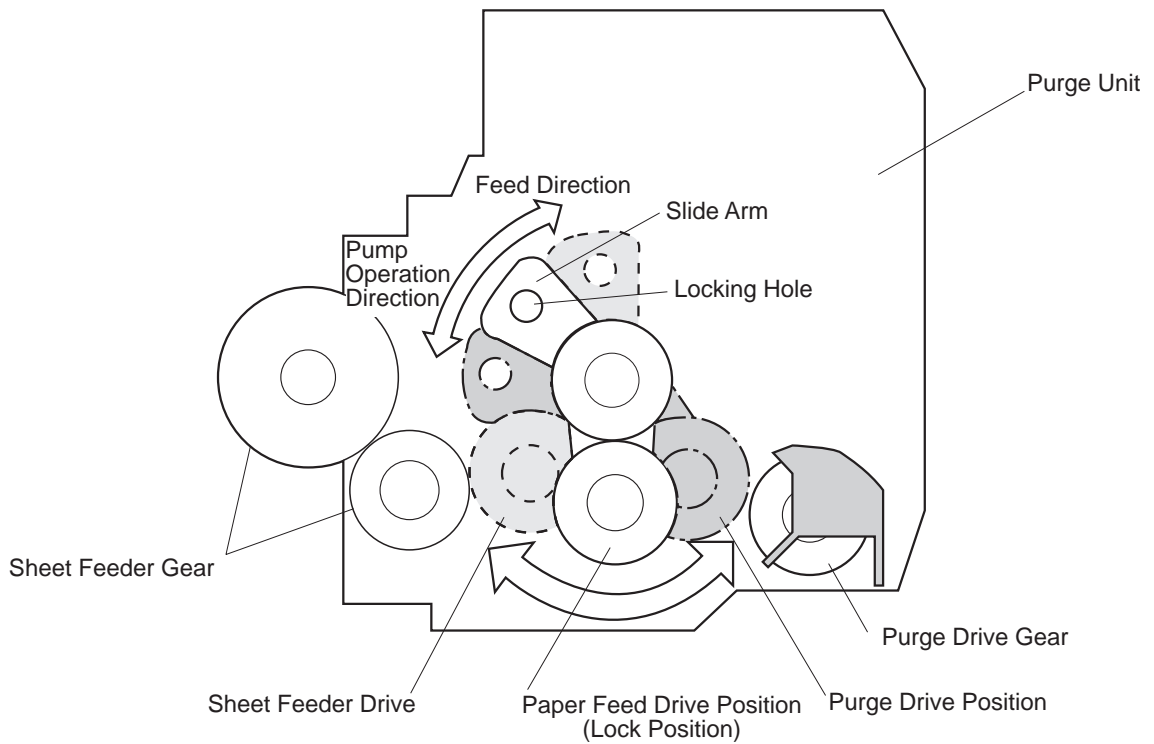

Figure 4-17 Paper Feed Motor Drive Transmission

3.5 Paper Feed

3.5.1 Outline of the paper feed

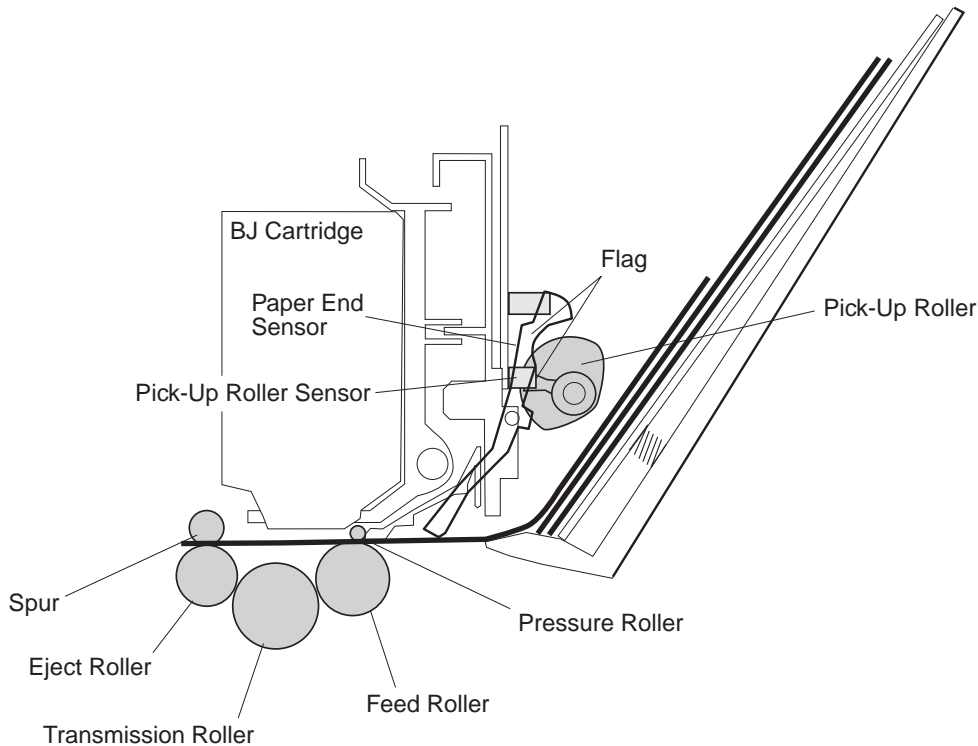

Figure 4-18 Paper Feed Mechanism

1) Paper feed mechanism

The paper feed mechanism supplies paper from the built-in cut-sheet feeder. The built-in cut sheet feeder is driven by the paper feed motor. Paper stacked in the sheet feeder is picked up and fed automatically. Even thick paper like envelopes can be fed automatically without selecting the paper type mechanically with the paper selection lever.

When the paper is sensed by the paper end sensor, it is fed automatically by the paper feed roller until it reaches the starting position for printing on the platen. During printing, the paper is fed by the rotation of the paper feed roller. The paper, after printing, is delivered by the eject roller.

2) Paper feed operation

It is not possible to perform paper feed operations with the printer, however, paper ejection can be performed with the *RESET* button, when delivered out.

3.5.2 Structure of the sheet feeder

This printer has no paper selection lever on the cut sheet feeder.

If the paper meets specifications, it can be fed without selecting the paper type. The paper is loaded in the cut sheet feeder such that a corner of it is caught by the paper separator. When printing starts, the pick-up roller starts to rotate through the drive of the paper feed motor. Plain paper is fed with its corner held by the paper separator, and then pushed into the paper feed section. When printing on thick paper like envelopes, as the paper is stiffer than the return force of the paper separator's spring, the paper separator is pressed down to feed the paper.

The initial position of the pick-up roller is detected when the flag is sensed by the pick-up roller sensor on the logic board.

When paper is sensed by the paper end sensor for over a second, it is fed automatically until it reaches the starting position for printing.

When the paper pick-up operation is executed, if no paper is sensed, it is executed again. If the paper is still not sensed, it is assessed as a paper feed error.

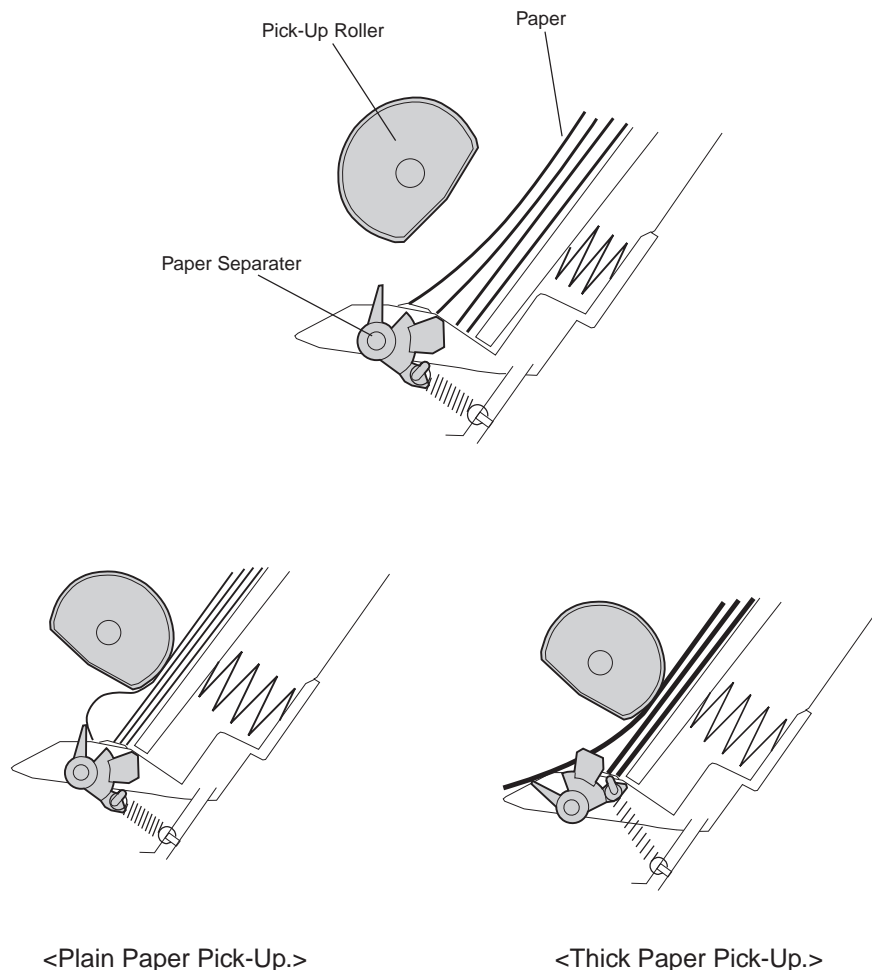

Figure 4-19 Paper Pick-up Mechanism

4. PRINTER ELECTRICAL SYSTEM

4.1 Overview

The electrical system functions are handled by the logic section or power supply. The logic section converts the data from the interface into print signals or printer operation signals and drives the BJ cartridge and motors while monitoring the status of the sensors.

The power supply unit consists of a built in AC adapter which provides DC output to the logic board, motors, and head etc. When DC input power from the AC adapter is being supplied, all of the hardware components are active.

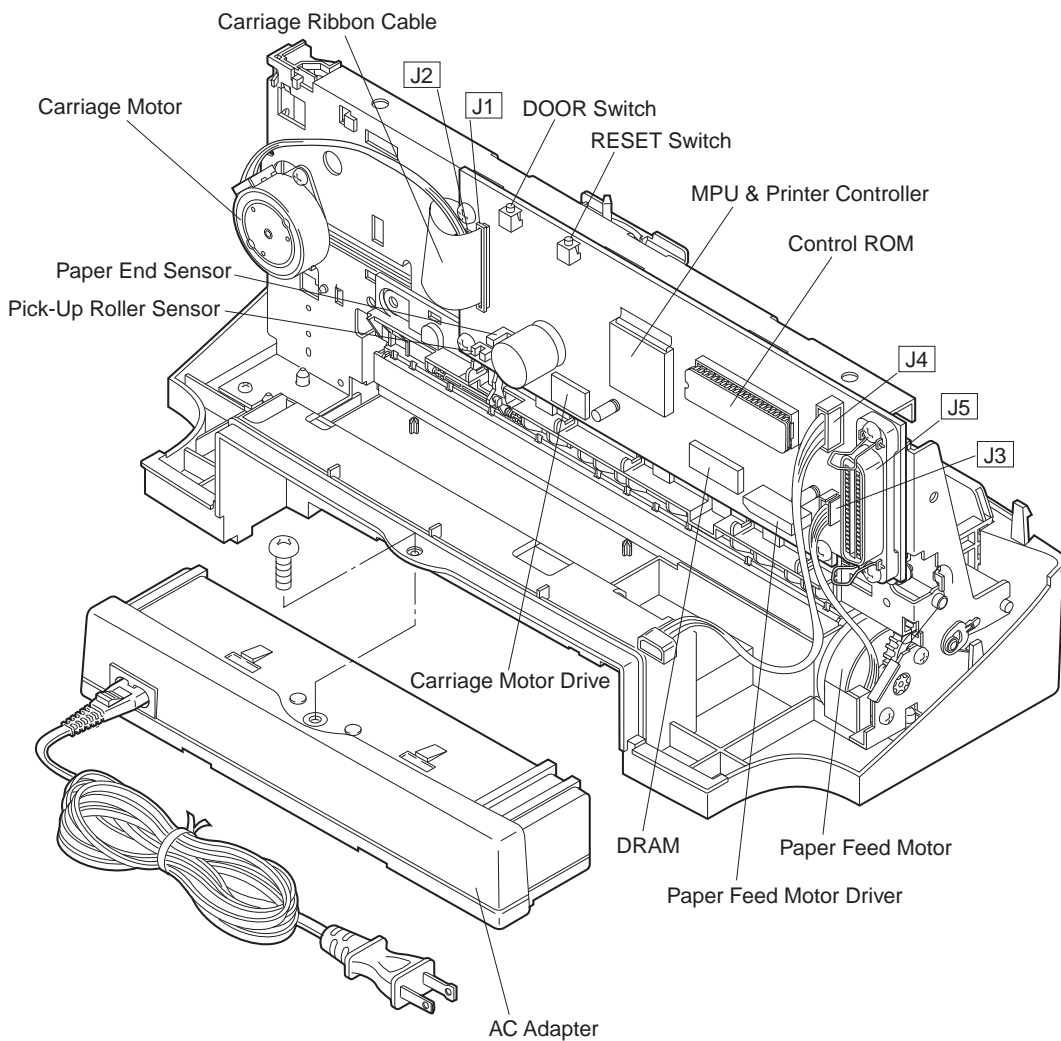

Figure 4-20 Printer Electrical System

4.2 Logic Section

4.2.1 Logic section block diagram

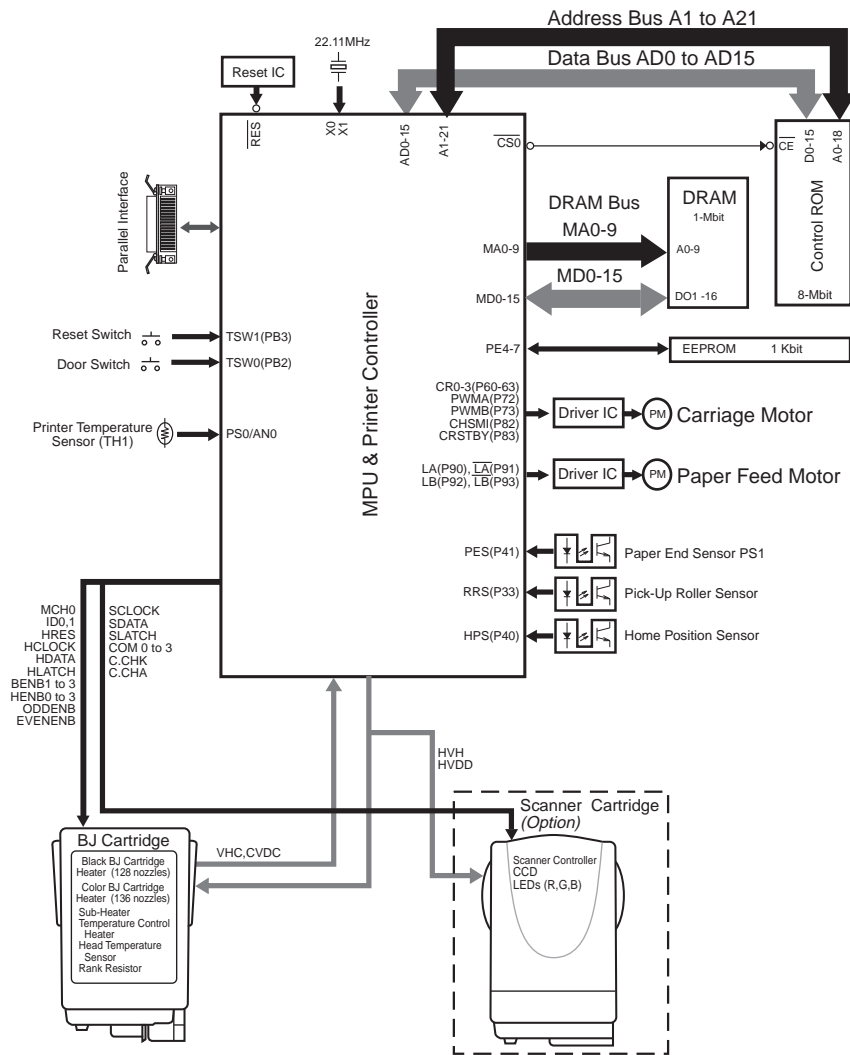

Figure 4-21 Logic Board Block Diagram

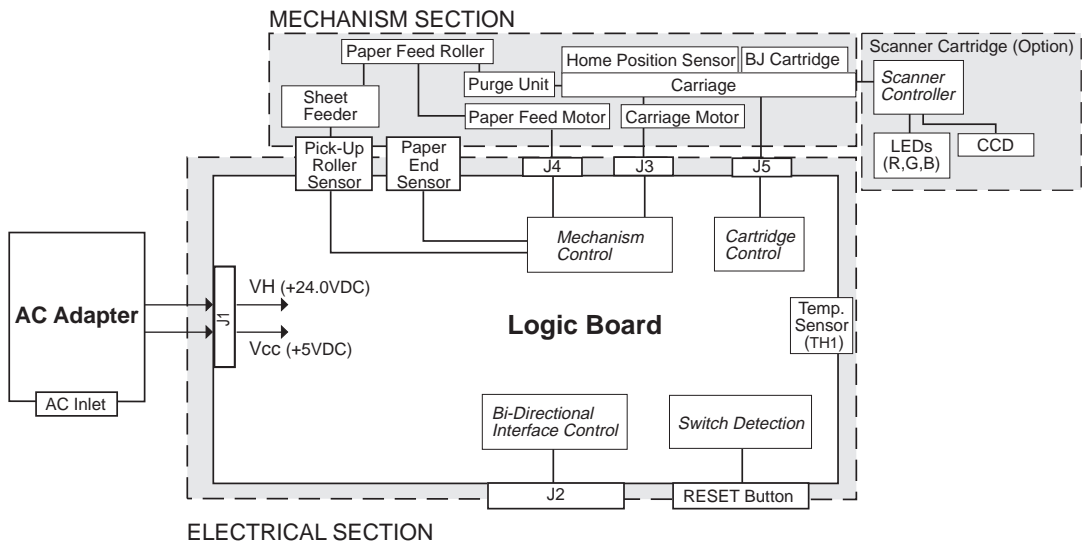

Figure 4-22 Printer Block Diagram

4.2.2 Logic section components

1) MPU & Printer controller (IC3)

The MPU & Printer controller contains a 16-bit CPU, 1K-bit RAM, 21-bit address bus port, 16-bit data bus port, stepping motor controller, interrupter controller, A-D converter, interface controller, print head controller, buffer controller, DRAM controller, EEPROM controller, I/O ports, and other components.

Built-in CPU

The 16-bit CPU operates in synchronization with a 20 MHz external clock input.

Address bus

The 21-bit address bus port is connected to an 8 M-bit control ROM. The controller synchronizes with the read signals output by the MPU and Printer controller.

Data bus

Like the address bus, the 16-bit data bus port is connected to the 8 M-bit control ROM.

Stepping motor controller

The stepping motor controller outputs the carriage motor single- and two-phase exciter drive signals and paper feed motor two-phase drive signals.

The stepping motor controller switches the carriage motor with the 5-step peak current value for optimum drive. The stepping motor controller outputs the switching control signal to the carriage motor driver.

A-D converter

The following analog signals are detected after they pass through the built-in A-D converter:

AN0: The printer's internal temperature is detected by the thermistor on the logic board.

AN1: The head temperature is detected by the head temperature sensor in the BJ cartridge.

AN3: The head rank is detected by the rank resistor in the BJ cartridge.

Interface controller

The interface controller receives, from the computer, 8-bit parallel data which is synchronized with the data strobe pulse ($\overline{\text{STROBE}}$) through the $\text{BUSY}/\overline{\text{ACKNLG}}$ handshake. It also controls other interface signals.

The data received through the interface is stored in the DRAM's receive buffer and analyzed by the MPU.

When the printer initialization signal $\overline{\text{INIT}}$ is input through the interface to the printer controller, the printer controller outputs a BUSY signal. Also, after INT1 is output to the MPU and print data in the print buffer is printed, the printer is initialized.

DRAM controller

The DRAM controller controls the 10-bit address/16 bit data bus of the 4 M bit DRAM, and also performs the read/write control, and refresh control.

Buffer controller

The buffer controller automatically writes the received data to the receive buffer in the DRAM, manages the remaining capacity of the print buffer, and clears the data after it is read.

Print head controller

The print head controller converts the print data read from the DRAM's print buffer from parallel to serial and sends it to the print head. At the same time, the printed dots are counted for the variable control of the Heat-enable (H ENB) signal pulse width.

The head-driving signals consist of the block enable signals (B ENB 1, 2, 3), odd/even enable signals (OddENB/EvenENB), and heat enable signals (H ENB 0, 1, 2, 3). The block enable signals and odd/even enable signals specify the block for time-shared drive. The heat enable signals control the eject heater's conduction time.

I/O port

Signals for the setting statuses determined by the *RESET* button, cover open switch, head temperature sensor, head ID, paper end sensor, home position sensor, and pick-up roller sensor are input through the input ports.

Signals for operations such as BJ cartridge detection and head-driving voltage control are output from the output ports.

2) Control ROM (IC4)

The 8 M-bit control ROM contains the printer control program .

3) DRAM (IC5)

Controlled by the MPU & Printer controller, the 4 M-bit DRAM is used as a print buffer and working area.

4) Reset IC (IC2)

This IC detects the power voltage when power on or instantaneous power failure occur and resets the MPU & Printer controller.

5) EEPROM (IC1)

Controlled by the MPU & Printer controller, the 1 K-bit EEPROM (Electrically Erasable and Programmable ROM) stores various function settings such as the total count of printed sheets and the total waste ink amount.

6) Paper feed motor driver (IC7)

Controlled by the MPU & Printer controller, the paper feed motor driver drives the paper feed motor (controlled by the two-phase exciter) with a constant-voltage unipolar drive. The driving IC has four identical circuits.

7) Carriage motor driver (IC6)

Controlled by the MPU & Printer controller, the carriage motor driver drives the carriage motor (controlled by the one to two-phase exciter) with a fixed current bipolar drive. In accordance with the switching signal from the MPU & Printer controller, the peak current value is set to five steps and driven. The driving IC has two identical circuits.

5. SENSOR FUNCTIONS

The printer has a pick-up roller sensor, paper end sensor, home position sensor (purge sensor), printer temperature sensor, and head temperature sensor. Furthermore, the EEPROM counts and records the waste ink absorption amount. When the waste ink absorber becomes full, the waste ink absorption amount indicates an error.

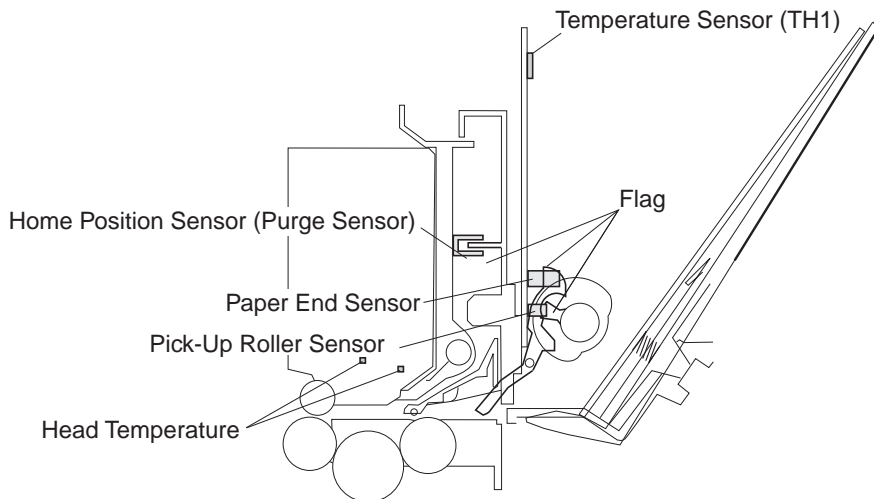

Figure 4-23 Sensors

5.1 Pick-up Roller Sensor

The photo interrupter-type pick-up roller sensor detects the initial position of the sheet feeder pickup roller. When the initial position is detected, the flag interrupts the sensor.

5.2 Paper End Sensor

The photo interrupter-type paper end sensor detects with the paper sensor arm's flag the presence of paper when the edge of the paper sheet passes through the paper feeding mechanism. When there is no paper the sensor is closed, however the sensor is opened when paper is detected.

5.3 Home Position Sensor (Purge Sensor)

The photo interrupter-type home position sensor senses the home position edge and carriage position. After the edge is detected, the carriage moves to the right. The position where the maintenance jet is executed becomes the home position. Also, at the capping position, the on/off of the purge sensor flag during the recovery operation is detected.

5.4 Temperature Sensor

The temperature sensor is a thermistor which detects the printer's internal temperature. The thermistor resistance fluctuates with any temperature changes. The change in resistance is detected as a change in the voltage by the MPU. The analog value input to the MPU is converted into a digital value by the internal A-D converter to detect the temperature. After the printer temperature is detected, the head-driving and head temperature adjustment signals are controlled accordingly.

5.5 Head Temperature Sensor

The head temperature sensor in the print head is a diode sensor which detects the head's internal temperature. Temperature changes in the head are detected by the MPU as voltage-level changes.

The analog value input to the MPU is converted into a digital value by the A-D converter. This digital value is used for stopping dot ejection if there is an abnormal temperature increase.

5.6 Waste Ink Amount Detection

Waste ink is discharged during head maintenance and absorbed by the waste ink absorber.

If the amount of waste ink discharged exceeds the absorption capacity of the waste ink absorber, ink might leak from the printer.

To prevent ink from leaking, the waste ink absorber capacity is estimated and detected when full.

The waste ink is discharged during maintenance jet and cleaning. The amount of waste ink discharged is estimated by counting the number of maintenance jet and cleaning operations. Then the waste ink amount is calculated taking into consideration the amount of evaporated ink. When the calculated waste ink amount exceeds the capacity of the waste ink absorber, a waste ink-full error occurs.

TABLE 4-4 LIST OF SENSOR FUNCTIONS

Sensor Function	Description	Status
Paper detection	Detected by the paper sensor	Provided
Paper width detection		Not provided
Home position detection	Detected by the home position sensor	Provided
Cartridge detection	Detected by the head rank resistance and head temperature sensor	Provided
Ink cartridge detection		Not provided
Cartridge identification	Identified by the head's ID0, ID1 and INKS2	Provided
Waste ink amount detection	Calculated with the maintenance jet dot count	Provided

6. SCANNER CARTRIDGE

6.1 Scanner Cartridge Overview

The scanner cartridge is a replaceable scanner unit that carries a one-line 128 pixel CCD. The scanner separates each of the three RGB primary colors of the LED by scanning the same line three times. The color image is output by 8-bit signals, 256 gradation in each RGB color. For a monochrome image, the image is lit with a green LED and scanned once to output either an 8-bit or 2-bit signal. The maximum scanning resolution is 360 dpi X 360 dpi.

The light source LED within the scanner lights up and illuminates the document on the platen. The light rays hit the image and, using an imaging lens, the reflected light rays are converged onto the CCD sensors. The converged light rays are converted to analog signals by the CCD. After the analog signals have been converted to digital signals by the scanner controller, the scanned image is processed, and the image data is sent to the computer via the printer's bi-directional Centronics interface.

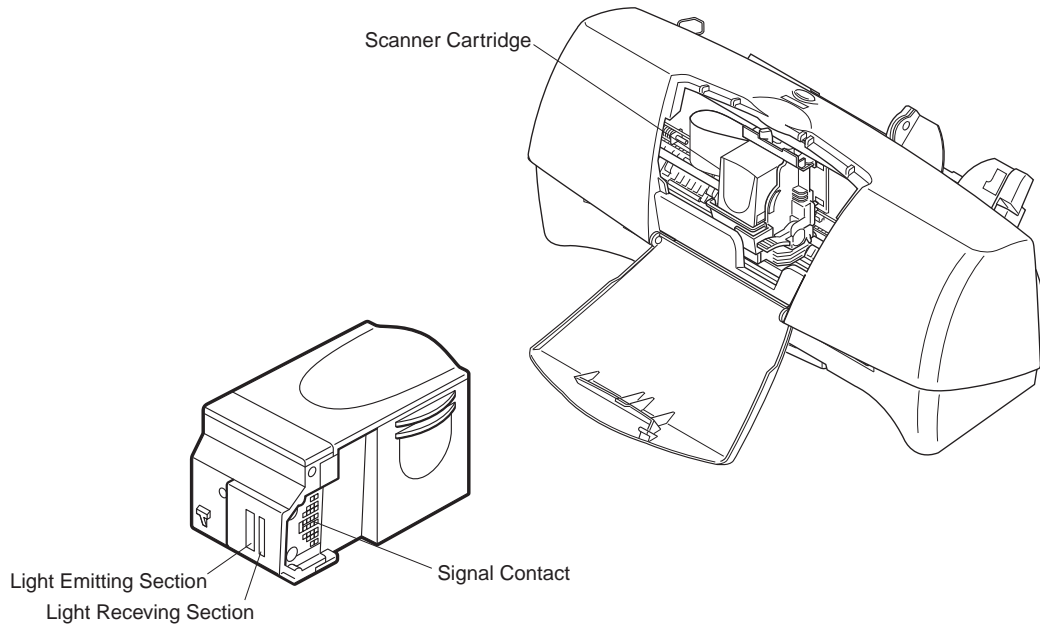

Figure 4-24 Scanner Cartridge

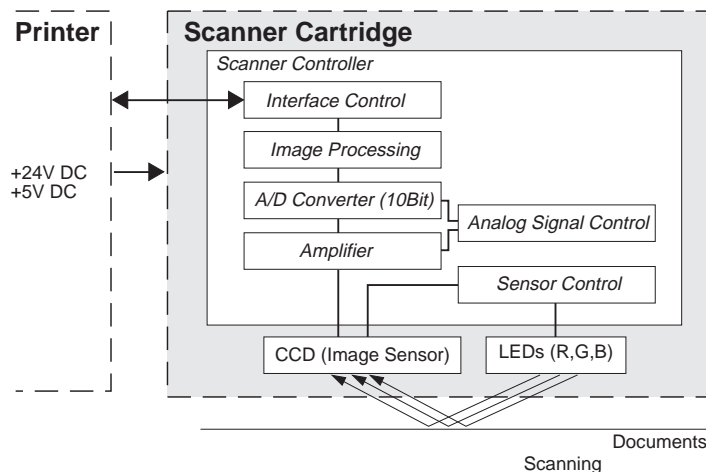

Figure 4-25 Block Diagram

6.1.1 Block Diagram 6.2 Scanner Cartridge Structure

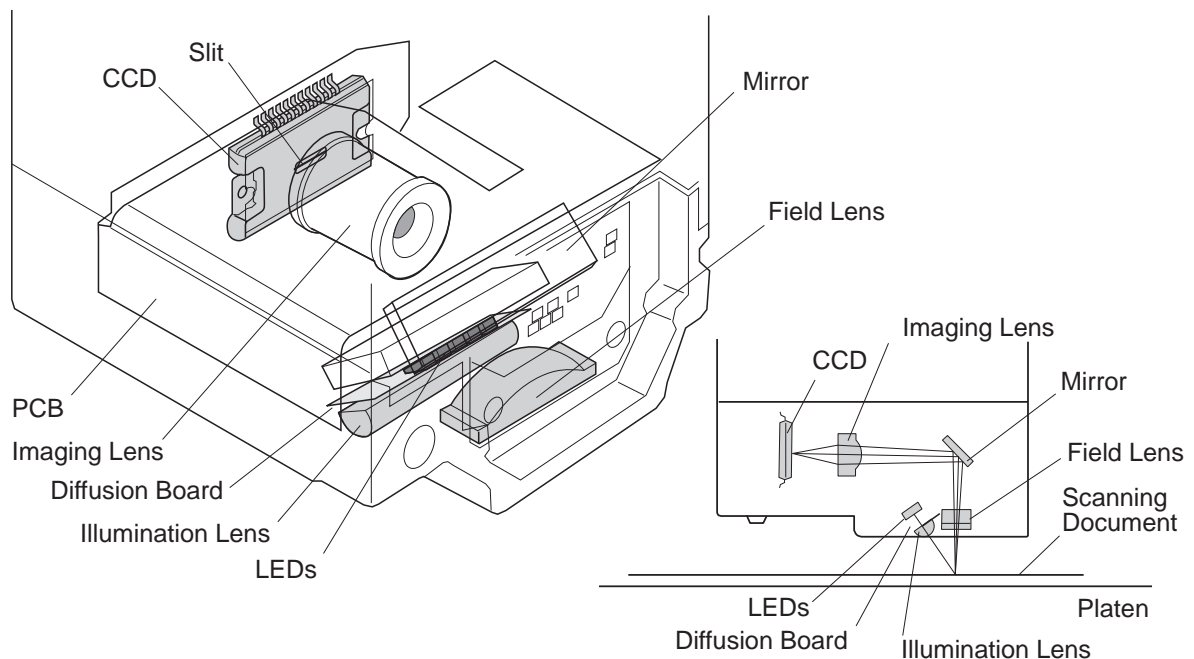

Figure 4-26 Scanner Cartridge

1) LED

Red, green and blue LEDs are used to illuminate the scanning document. To compensate for the low intensity of the red and green LED's, two red and green LEDs have been incorporated and a total of five LEDs are mounted on the scanner. Only the green LED is used for monochrome scanning.

2) Illumination lens

This "D" shaped lens converges the light from the LED light source.

3) Diffusion board

The light intensity of the LED is brighter at the center than at the ends. The diffusion board allows even distribution of light onto the document.

4) Field lens

This lens prevents any magnification reduction caused by paper gaps when scanning a lifted or bent document.

5) Imaging lens

This lens is used for forming an image of the light rays converged by the field lens onto the CCD.

6) Shading board

The shading board with a slit at the front surface of the CCD is used to prevent crosstalk generated in areas adjacent to high contrast areas.

7) CCD

The scanner cartridge uses a semiconductor type, one-line 128 pixel CCD (Charge Coupled Device). Depending on the light amount of the image formed on the CCD, electric voltage signals are sent to the scanner controller as image signals.

8) Scanner controller

The scanner controller is an IC that controls the CCD and processes the analog signal output from the CCD. The scanner controller also controls the following image processing:

- **Black Level Correction**
The black level is set to maximum CCD output.
- **A/D Converter**
The A/D converter converts the image signals to 10-bit image data.
- **Shading Correction**
The variation of the image signal is corrected by the shading correction. Due to (i) the variation of the sensitivities of the CCD sensor elements and (ii) the uneven distribution of light transmitted through the center and the periphery of the lenses, variation in image density may occur between each line in the feeding direction of paper. The scanned data is compared against a standard white data to even out and correct the density.
- **White Balance Correction**
Variation in image density, which may occur due to changes in the amount of LED light caused by temperature change, in the direction of the carriage length, is corrected.
- **Carriage Scanning Direction Resolution Converter**
The carriage scanning direction resolution converter converts the resolution of the output in the scanning direction according to the carriage direction.
- **Edge emphasis**
- **Binary image processing function**
The scanner controller has a built-in SRAM used for output buffer memory.



The scanner cartridge cannot be disassembled or reassembled. As the imaging lens is used for forming an image on the CCD, it is moved from its fixed position to adjust the optical path for focusing. Focusing cannot be conducted during servicing.

6.3 Signal Contacts

The scanner cartridge is recognized by TOP.S, DIAS, and CCHK signals. The scanned image output to the printer is transmitted with a SCLOCK signal in sync with a SDATA signal. The scanner is controlled by the internal register setting signals, CMD0, 1, 2 and 3.

For the location and assignment of signals, refer to *Part 5: 6.3 BJ Cartridge & Scanner Cartridge (page 5-26)*.

6.4 Scan Mode

TABLE 4-5 LIST OF SCAN MODE

Scanning resolution	Scanning Image Pixel Width			Carriage Speed
	Color	Black & White		
	Multi Value	Multi Value	Binary	
360 X 360	48	48	128	4.88 kHz
300 X 360	48	48	128	5.2 kHz
200 X 360	64	112	128	5.2 kHz
200 X 180	64	128	128	5.2 kHz
180 X 180	64	128	128	6.5 kHz
90 X 90	64	128	128	9.19 kHz

6.5 Calibration

Calibration is performed by using the white calibration sheet. In the calibration process, to create calibration data, data such as the printer's internal temperature, black level data, and white standard data used as a reference in scanning, are sampled and then corrected in terms of shading and white balance.

The scanner application retains the past 5 calibration data samples and saves them in a file.

When a scanning operation is performed, a value from the compiled temperature data that is within $\pm 5^{\circ}\text{C}$ of the printer's internal temperature at the time is downloaded to the scanner controller. The scanner application requests calibration when there is no compiled data within $\pm 5^{\circ}\text{C}$.

This page intentionally left blank



Part 5

MAINTENANCE

Page	
5 - 1	1. MAINTENANCE
5 - 1	1.1 Parts for Regular Replacement
5 - 1	1.2 Consumables
5 - 1	1.3 Periodic Maintenance
5 - 2	2. SERVICING TOOLS
5 - 2	2.1 List of Tools
5 - 3	3. GREASE APPLICATION
5 - 4	4. DISASSEMBLY AND REASSEMBLY
5 - 4	4.1 Disassembly and Reassembly
5 - 4	4.2 Disassembly and Reassembly Cautions
5 - 5	4.3 Logic Board and Bottom Cover Replacement Cautions
5 - 6	5. TROUBLESHOOTING
5 - 6	5.1 Troubleshooting
5 - 8	5.2 Error Condition Diagnosis
5 -23	6. LOCATION & SIGNAL ASSIGNMENT
5 -23	6.1 Logic Board
5 -25	6.2 Carriage Ribbon Cable
5 -26	6.3 BJ Cartridge & Scanner Cartridge
5 -28	7. CIRCUIT DIAGRAMS
5 -28	7.1 Parts Layout

1. MAINTENANCE

1.1 Parts for Regular Replacement

Level	Part
User	None
Service personnel	None

1.2 Consumables

Level	Consumable
User	Black BJ cartridge Color BJ cartridge Color ink cartridge/ Black ink cartridge Photo BJ cartridge
Service personnel	None

1.3 Periodic Maintenance

Level	Periodic Maintenance
User	None
Service personnel	None

2. SERVICING TOOLS

2.1 List of Tools

Ordinary Tool	Use
Phillips screwdriver	For removing screws
Blade screwdriver	For removing plastic parts
Tweezers	For installing and removing coil springs
Multi-meter	For troubleshooting

Special Tool (Parts Number)	Use
Grease MOLYKOTE PG-641 (CK-0562-000)	Apply to the specified place as shown in Figure 5-1

3. GREASE APPLICATION

Use the special tool to apply grease at the points and amounts shown below.

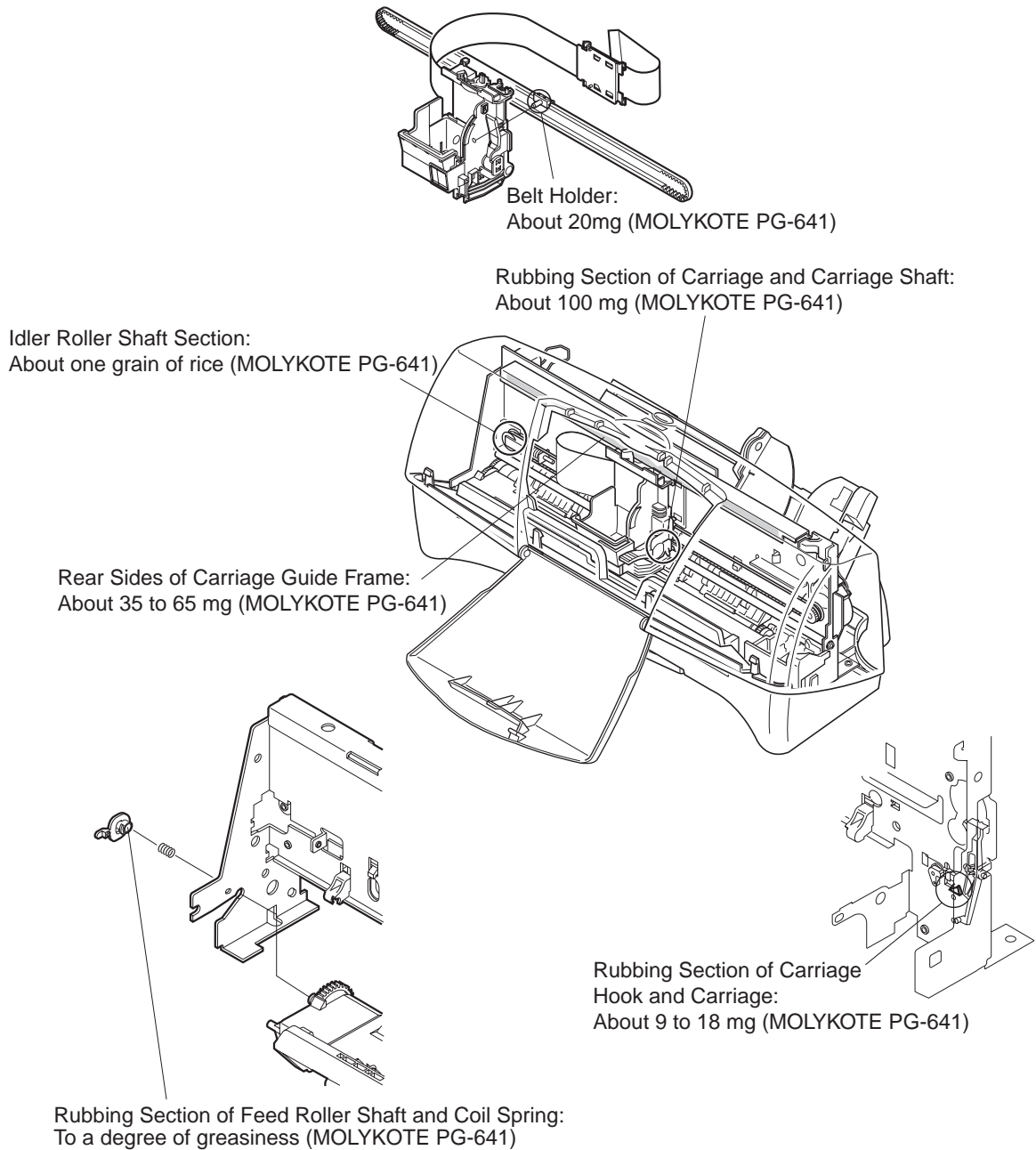

Figure 5-1 Grease Application Points

4. DISASSEMBLY AND REASSEMBLY

4.1 Disassembly and Reassembly

When disassembling or reassembling the printer, refer to the parts catalog. In the parts catalog, figure numbers are in the order of disassembly. Close-up diagrams are also provided for additional detail.

4.2 Disassembly and Reassembly Cautions

When disassembling or reassembling the printer, note the following precautions. These cautions are also provided in the parts catalog.

4.3 Logic Board and Bottom Cover Replacement Cautions

4.3.1 Logic board replacement cautions

The various settings, waste ink amount, and other data stored in the logic board's EEPROM cannot be rewritten into the new EEPROM after the logic board is replaced. The data in the new logic board's EEPROM is not set. After the logic board/EEPROM is replaced, reset the EEPROM as described in "Part 3: 2.4 EEPROM Reset" (page 3-19). When replacing the logic board, visually check the amount of waste ink in the waste ink absorber. Replace the bottom cover if necessary. Depending on the amount of waste ink already absorbed, ink may leak even before a waste ink-full error warning appears.

However, it is not necessary to replace it if the printer has been used for less than 2 weeks and less than 50 pages have been printed out.

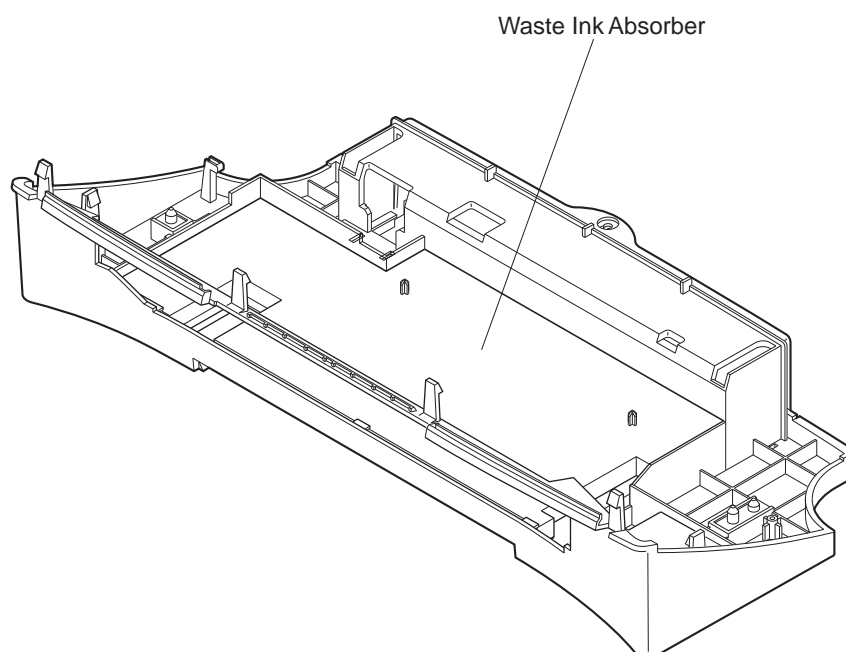

Figure 5-2 Bottom Cover

4.3.2 Cautions after replacing the bottom cover

After a waste ink-full error occurs and the bottom cover are replaced, reset the EEPROM.



When a waste ink-full error occurs, it can be assumed that the printer has printed more sheets than its service life called for. However, this depends on how many times the cartridge has been replaced and the usage conditions. When a color BJ cartridge is used, more ink is consumed due to head maintenance as compared to a black BJ cartridge. Therefore, the waste ink amount will also be more.

5. TROUBLESHOOTING

5.1 Troubleshooting

5.1.1 Overview

This chapter consists of the following two sections on subsequent pages: “Error condition diagnosis” for diagnosing the problem when the cause is unknown and “Symptoms” for resolving problems whose cause is known.

If the cause of the problem is unknown, diagnose the problem. And if the cause is known, follow the countermeasures to resolve the problem.

5.1.2 Troubleshooting cautions

1. Before troubleshooting, make sure the connectors and ribbon cable are properly connected. If the problem occurs at random, be sure to check the connections.
2. When servicing the printer with its outer casing removed and the AC adapter connected, beware of electrical shocks and PCB short circuiting.
3. Troubleshooting is described in flowchart form.

The following symbols are used in the flowcharts.

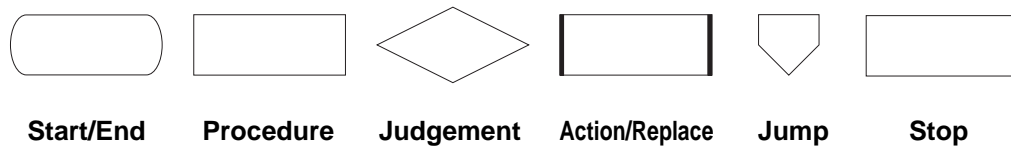

4. If there is a problem with the printing quality or paper feeding, first check that the printer’s installation location and paper meet the required specifications. Also check that the paper select lever and the paper thickness lever are set correctly and that the paper is loaded properly.

5. After replacing parts or repairing the printer, be sure to make a test print to confirm that the problem has been fixed.

If the problem still persists, troubleshoot again while skipping the steps already executed.

Example 1

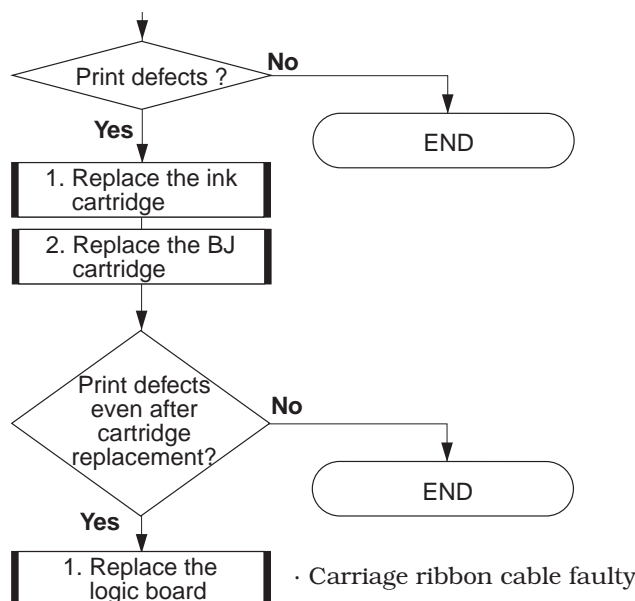

6. Some troubleshooting procedures include successive countermeasures. These are steps which must be followed to resolve the problem. After each countermeasure step, make a test print to confirm whether the problem has been corrected. If the problem persists, execute the subsequent countermeasure steps.

Example 2

Countermeasure 1: After replacing the BJ cartridge, execute a test printout to check whether the problem has been fixed.

If the problem persists, execute the next countermeasure step 2 which calls for the replacement of the logic board.

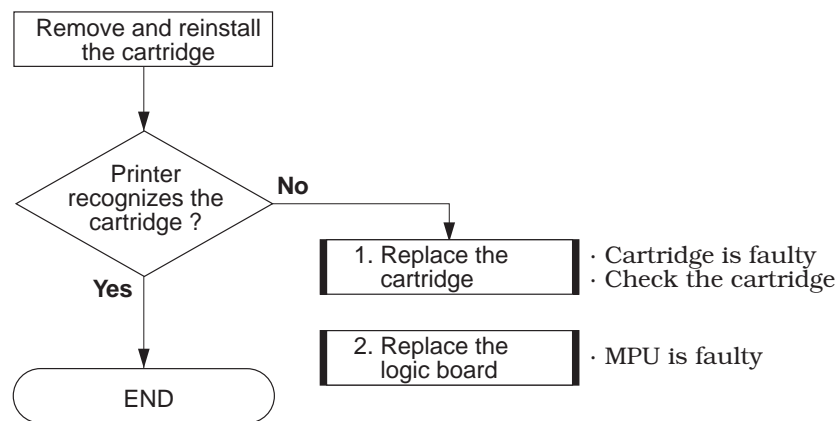

7. Ink cartridge replacement as a countermeasure is only applicable after the color BJ cartridge has been used for the Symptom. When using the black BJ cartridge for troubleshooting, advance to the next step.
8. After completing the troubleshooting, be sure to reconnect connectors and tighten any loosened screws.



When replacing the logic board, be sure to check the waste ink absorbers' ink amount on the rear of the printer base unit. If necessary, reset the EEPROM.

Refer to *Part 3, 2.4 EEPROM Reset (page 3-19)* and *Part 5, 4.3 Logic Board and Bottom Cover Replacement Cautions (page 5-5)*.

5.2 Error Condition Diagnosis

5.2.1 Initial self check

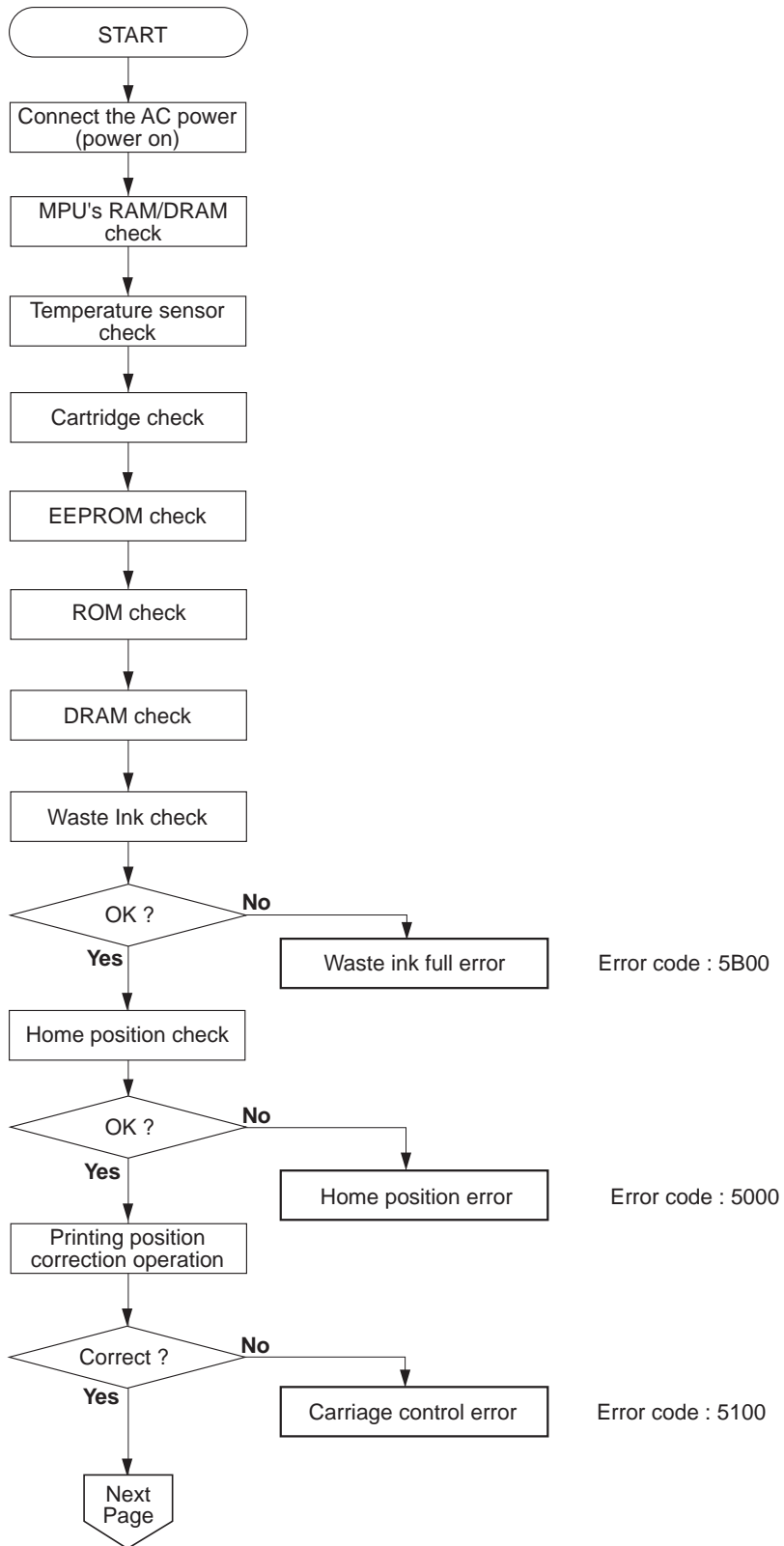

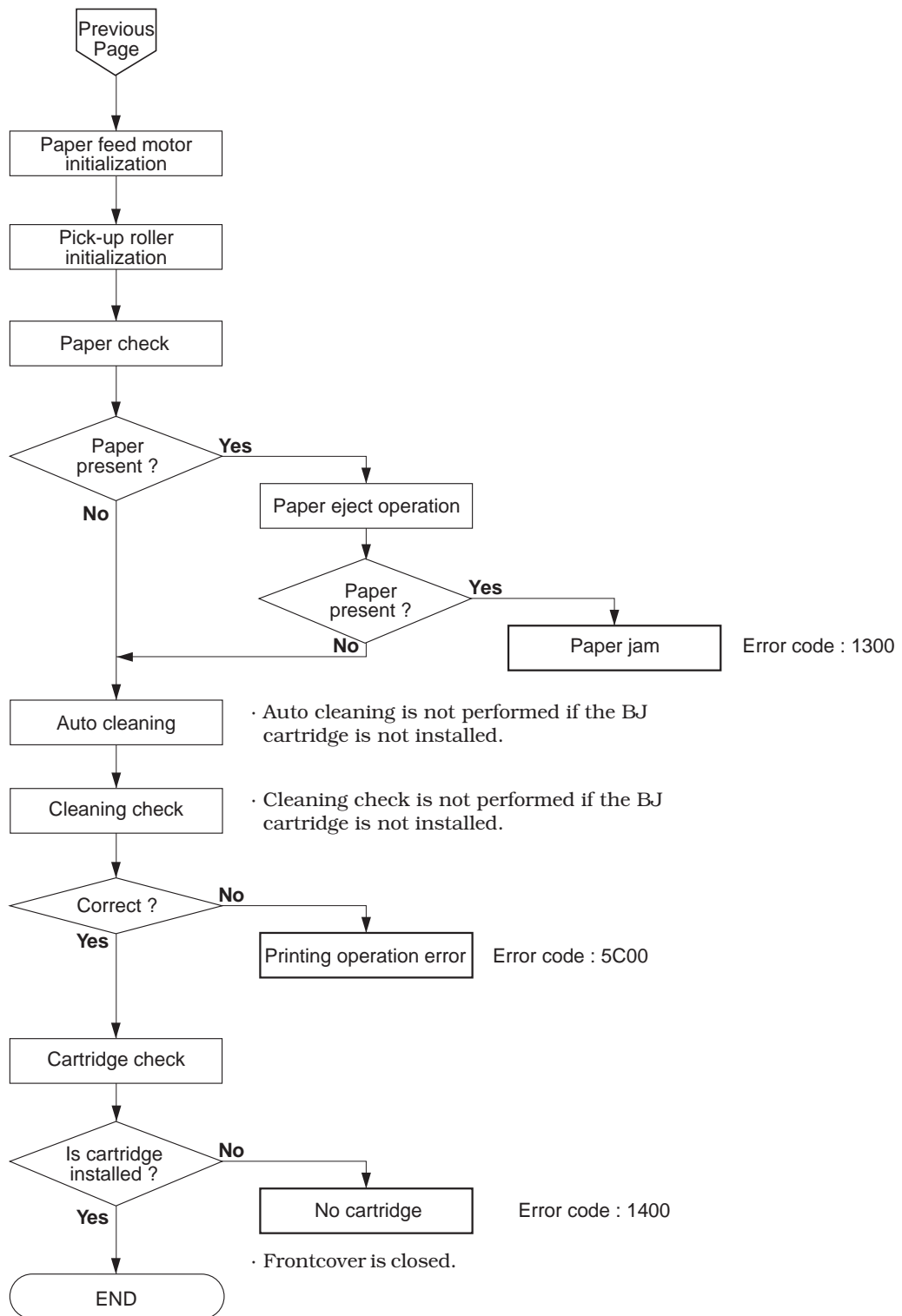

5.2.2 Error recovery

a) Error display

1.No Cartridge Error

<Cause> The cartridge is not installed correctly in the cartridge replacement position.

<Suspected Parts> Cartridge, logic board, carriage connector

<Measure>

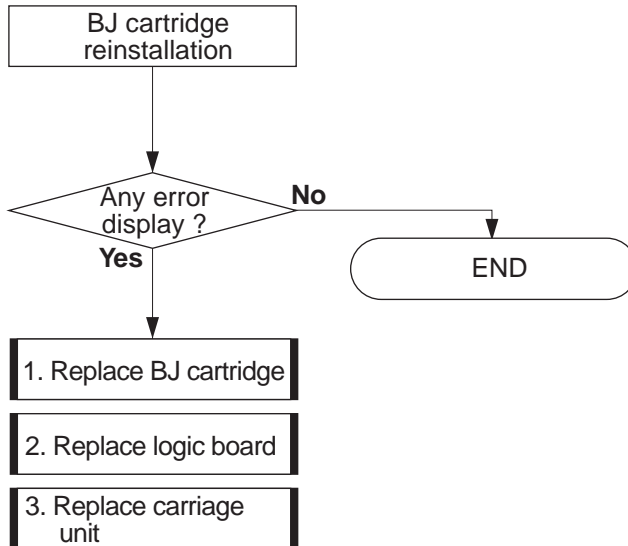

2.Home Position Error

<Cause> The home position cannot be detected.
<Suspected Parts> Home position sensor, carriage motor, logic board, carriage ribbon cable

<Measure>

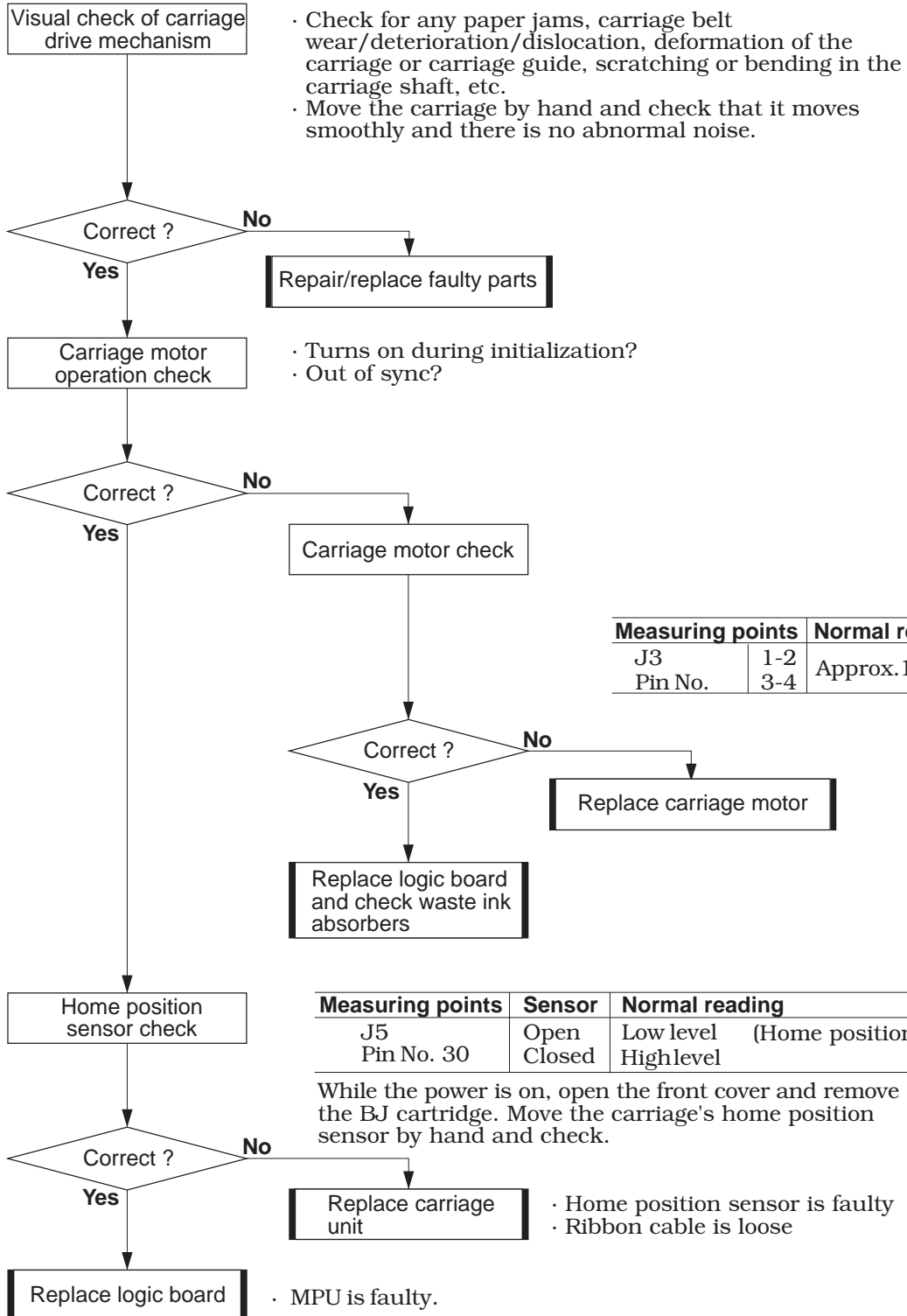

3. Paper Feed Error/Paper Jam

- <Cause>**
- The paper feed operation is executed but the paper is not fed.
 - The paper eject operation is executed but the paper is not ejected.

<Suspected Parts> Paper feed mechanism, pick-up roller sensor, paper end sensor, logic board

<Measure>

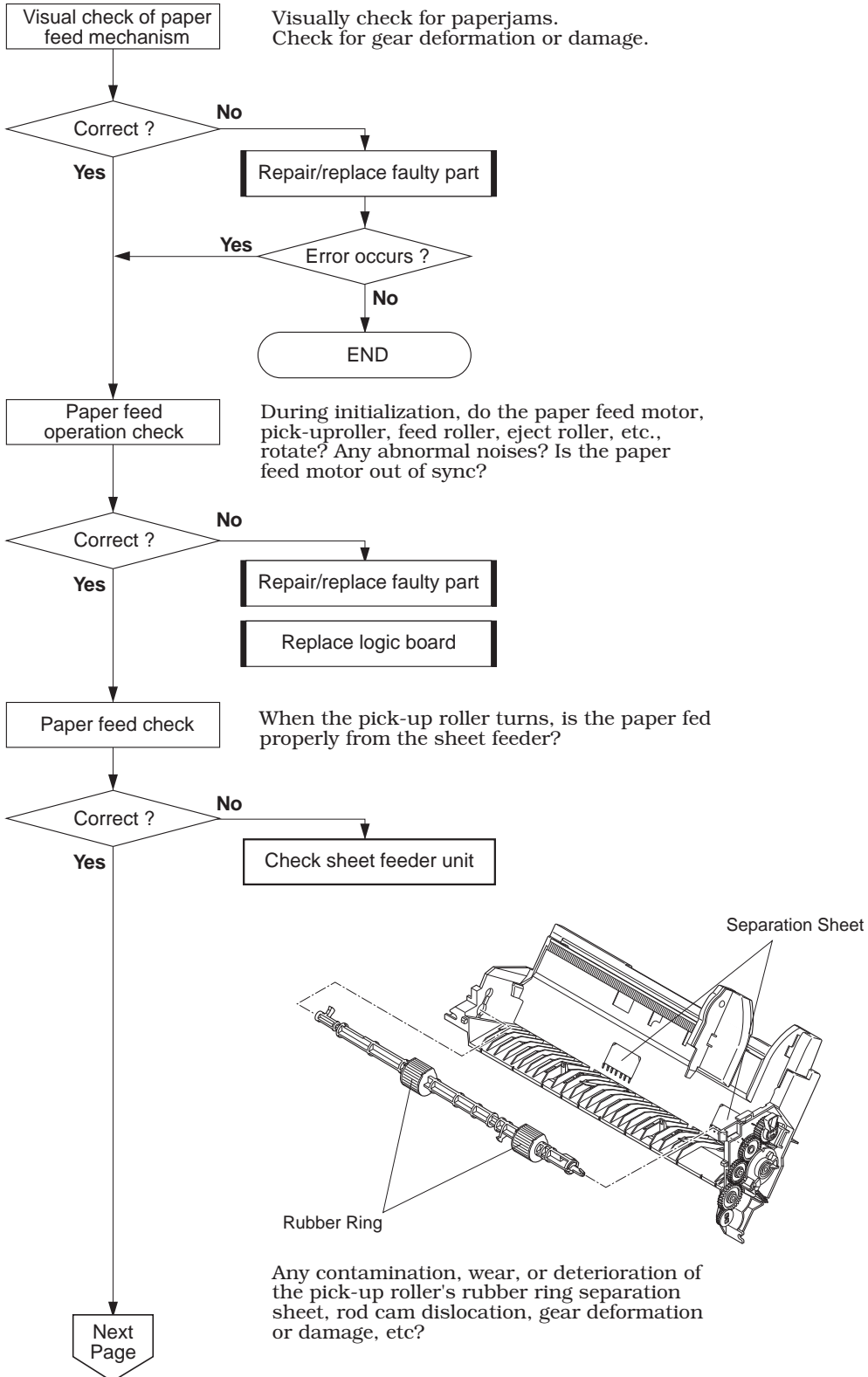

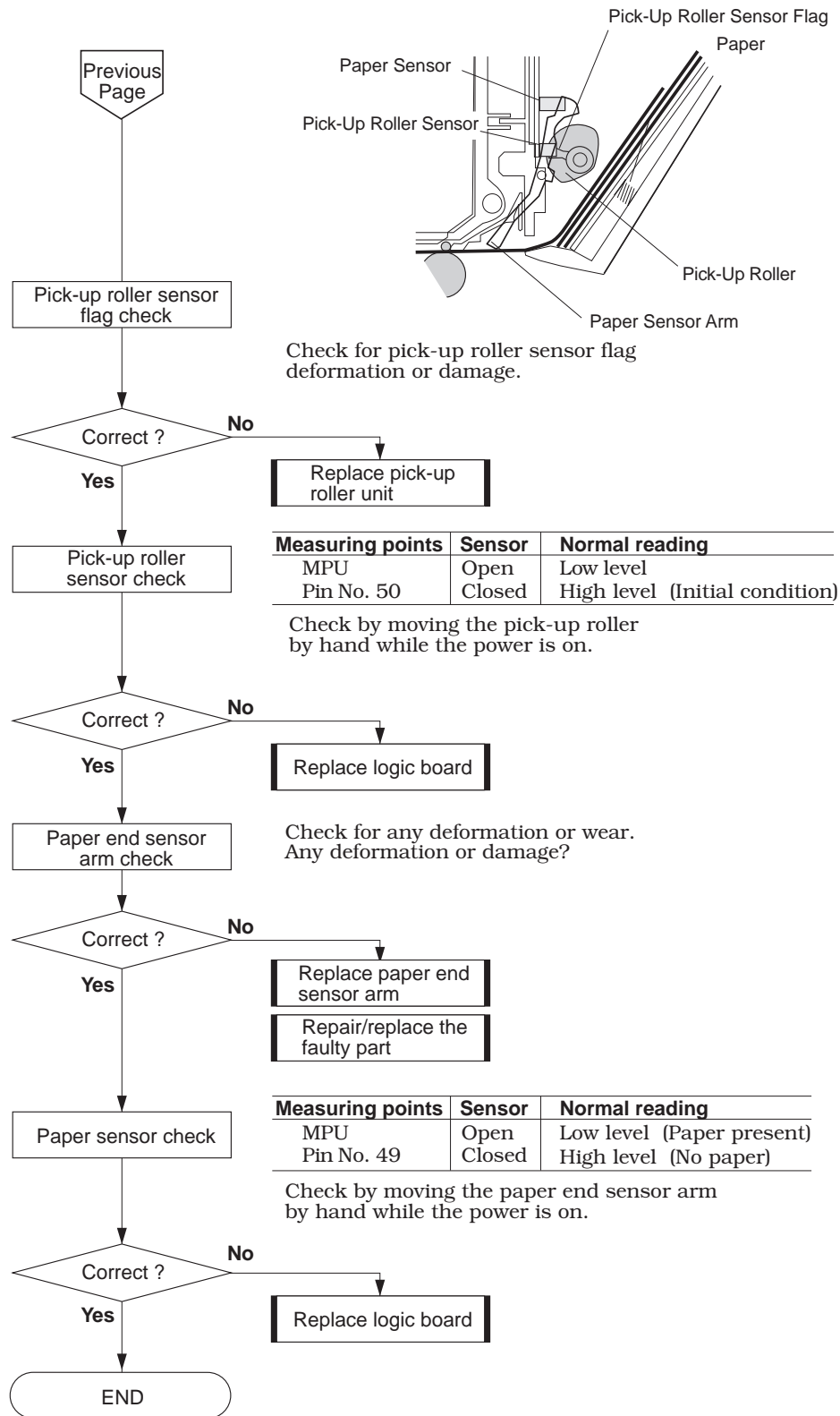

4. Waste Ink Full Error

<Cause> The waste ink absorbers' estimated waste ink amount has reached 100%.

<Suspected Parts> Waste ink absorbers, logic board

<Measures> 1. Reset the EEPROM and replace the bottom cover unit.
2. Replace logic board.

5. Temperature Sensor Error

<Cause> Thermistor is abnormal.

<Suspected Parts> Thermistor

<Measures> Replace logic board.

6. Carriage Control Error

<Cause> The printing position correction value cannot be detected.

<Suspected Parts> Carriage motor, logic board, home position sensor

<Measures> See countermeasures for home position sensor error.

7. Head Temperature Error/Head Temperature Sensor Error

<Cause> The head temperature is abnormally high.
<Suspected Parts> BJ cartridge, logic board

<Measure>

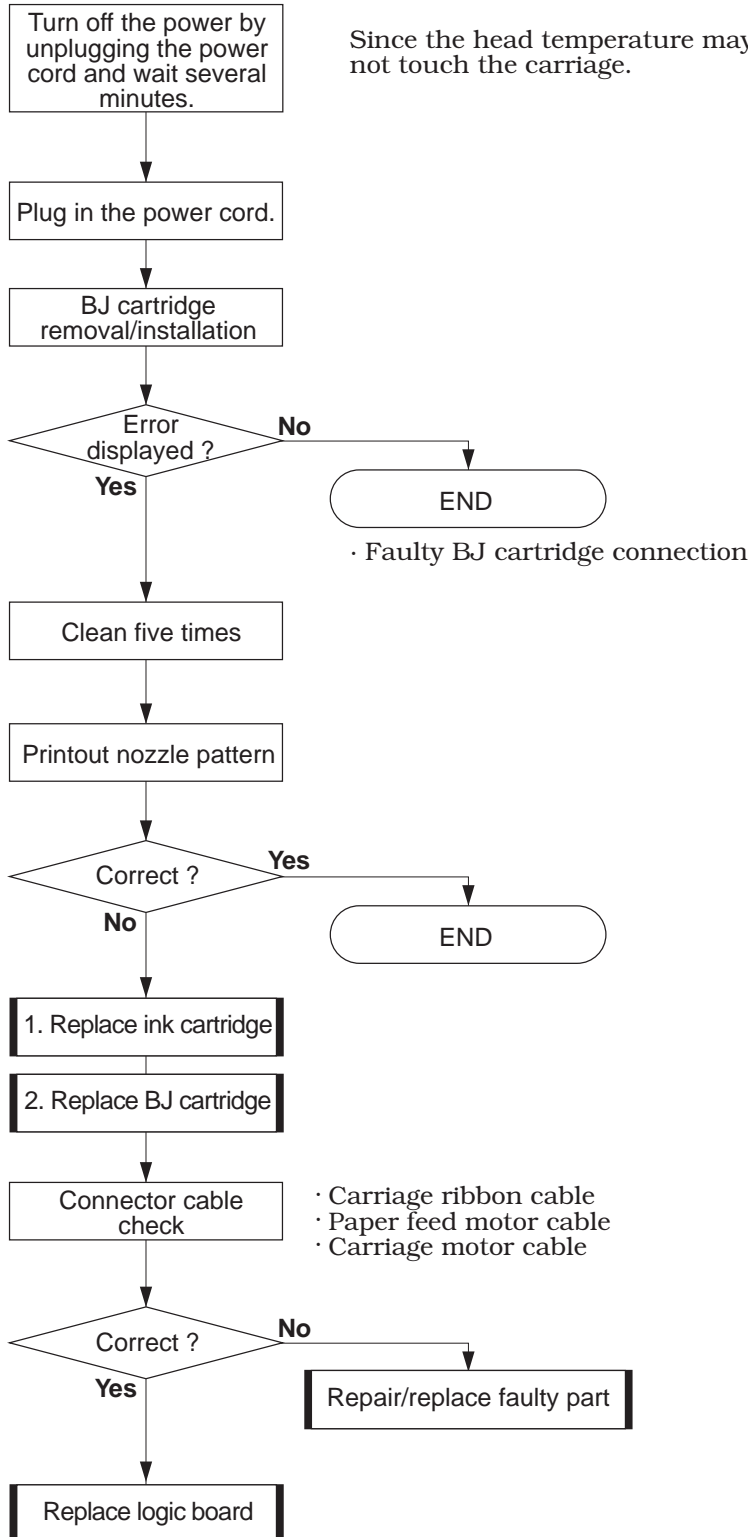

Since the head temperature maybe high, do not touch the carriage.

8. Cleaning Error

<Cause> Cleaning is not executed properly or not being detected.
<Suspected Parts> Home position sensor, sensor arm, purge unit, carriage ribbon cable, logic board

<Measure>

Visual check of paper feed system operation

During initialization, do the paper feed motor, pick-up roller, feed roller, eject roller, etc., rotate? Any abnormal noises? Is the paper feed motor out of sync?

Correct?

- No**
- 1. Repair/Replace faulty part
 - 2. Replace logic board

Yes

Sensor arm check

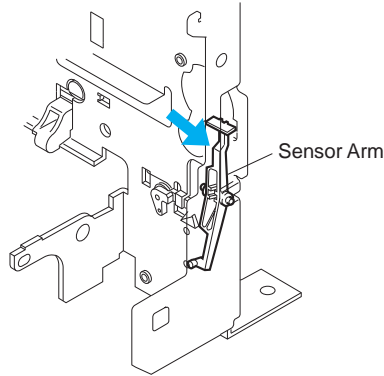

Move it by hand and see if it moves smoothly. Also, any deformation or damage at the locations indicated by the arrow?

Correct?

- No**
- Replace sensor arm or repair/replace faulty part

Yes

Purge unit check

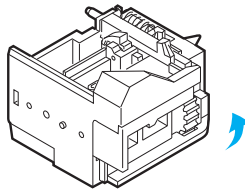

Remove the purge unit and move it as shown by the arrow to check if it moves smoothly. Any gear deformation or damage?

Correct?

- No**
- Replace purge unit

Yes

Disassemble and check the paper feed motor drive switching mechanism

If the gear is deformed or damaged, disassemble and check the paper feed motor drive switching mechanism refer to Part 4: 3.4.2 4) Switching the paper feed motor drive transmission (page 4-21).

9. Scanner Cartridge Error

<Cause> Incorrect Scanner ID in spite of Scanner cartridge recognition.
Incorrect calibration data sent from the computer.

<Suspected Parts> Scanner cartridge's controller. Scanner cartridge's RAM.

<Measure> Replace scanner cartridge.

b) Symptoms

1. The Power Does Not Turn On

<Symptom> The printer does not perform initializing even when the AC plug is connected.

<Cause> The AC adapter and/or control board is faulty.

<Measure>

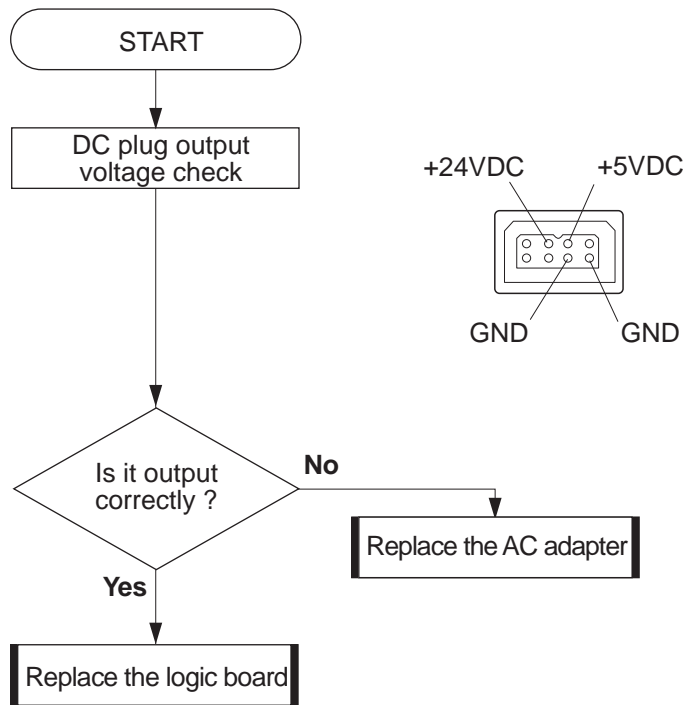

2. The Printer Does Not Recognize The Cartridge

- <Symptom>**
- The cartridge installed is not recognized.
 - When a cartridge is installed, the carriage moves to the replacement position.
 - The installed cartridge is recognized incorrectly.
- <Cause>**
- Faulty contacts between the cartridge and carriage.
 - The cartridge is faulty.
 - The carriage ribbon cable is faulty.
 - The logic board is faulty.

<Measure>

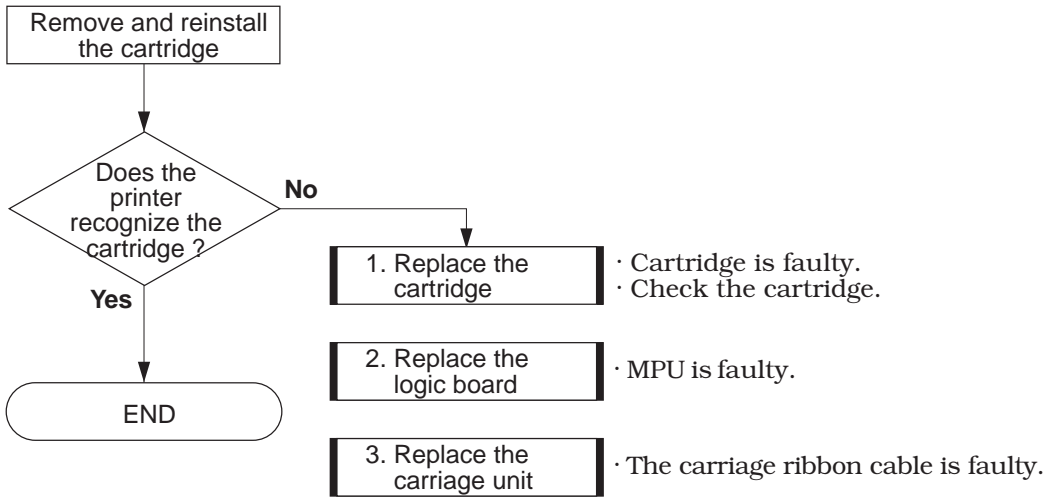

To confirm that the cartridge is not being recognized correctly, check for conductivity at the check points indicated in the diagram below.

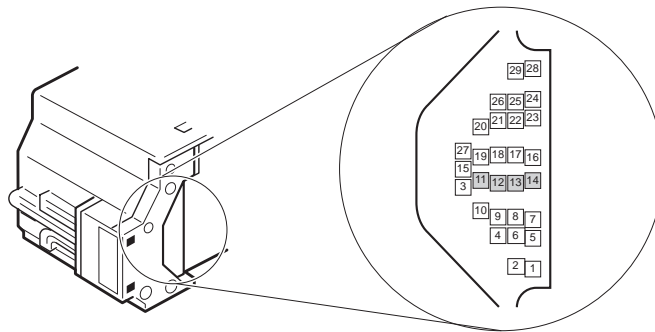

Black BJ Cartridge

Check	Normal reading
Pin No. 11-14	Approx. 0 Ω
Pin No. 12-14	
Pin No. 13-14	

Color BJ Cartridge (Multi-Drop)

Check	Normal reading
Pin No. 11-14	∞
Pin No. 12-14	Approx. 0 Ω
Pin No. 13-14	Approx. 0 Ω

Photo BJ Cartridge (Multi-Drop)

Check	Normal reading
Pin No. 11-14	∞
Pin No. 12-14	Approx. 0 Ω
Pin No. 13-14	

Scanner Cartridge (Option)

Check	Normal reading
Pin No. 11-14	∞
Pin No. 12-14	Approx. 0 Ω
Pin No. 13-14	∞

3. Faulty Printing <1>: No Printing

- <Symptom>**
- The printer does not print at all.
 - Printing stops mid-way.
 - Only a certain color is printed.
- <Cause>**
- The ink has run out or the BJ cartridge is faulty.
 - The control board, the carriage ribbon cable, or the purge unit is faulty.

<Measure>

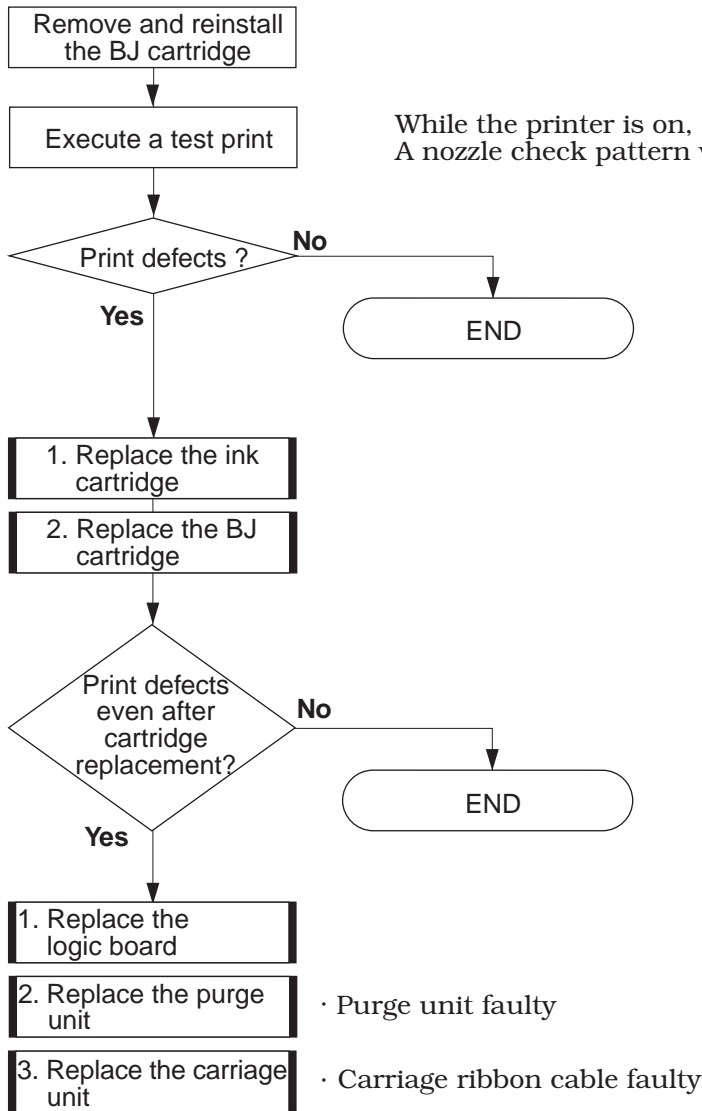

4 Faulty Printing <2>: White Stripes Appear

- <Symptom>**
- There is blotching.
 - There are white stripes.
 - The specified dots are not printed.
- <Cause>**
- The BJ cartridge or cartridge contacts are faulty.
 - The carriage ribbon cable is faulty.
 - The purge unit or paper feed mechanism (missing gear tooth) is faulty.

<Measure>

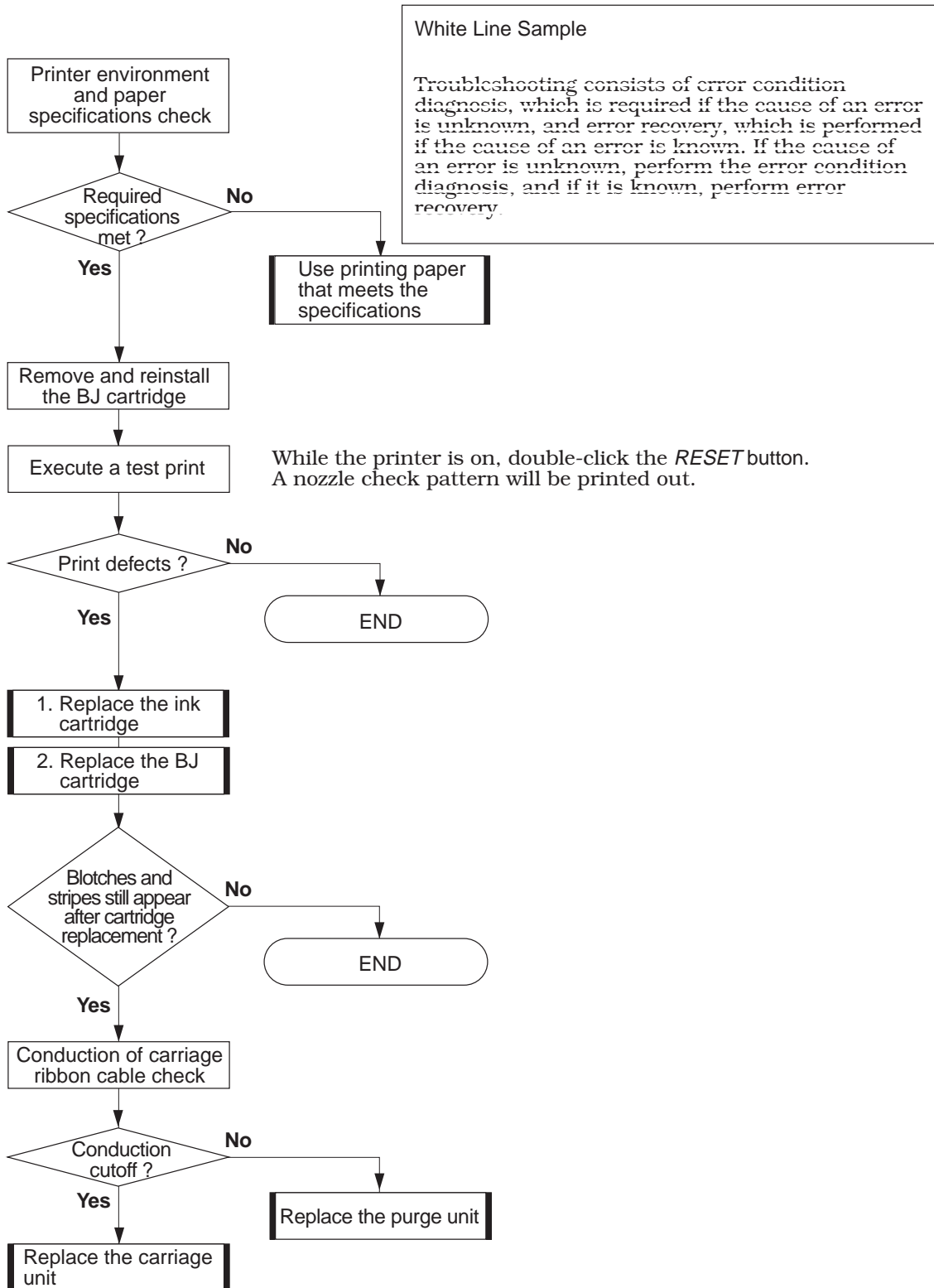

5 Faulty Printing <3>: Other Print Problems

Symptom	Check Item	Measures
Paper contamination	Ink mist on the platen.	Use a soft cloth moistened with water to clean.
	Ink has clogged around the head's nozzles. (No paper contamination during paper feeding and discharging.)	Clean a few times. If problem persists, replace the BJ cartridge.
	Ink has clogged (or paper bits have stuck) around the purge unit's head wiper or head capping area.	Replace the purge unit.
	Ink has adhered to the paper transport system. (The paper is already contaminated by the time it reaches the platen.)	Disassemble the paper transport system and use a soft moist cloth to clean.
Spur tracks appear	Ink has adhered to the spurs.	Use a soft toothbrush to clean.
	The spurs have deformed.	Replace the paper feed unit.
Vertically-oriented printed lines are misaligned.	The BJ cartridge is installed incorrectly.	Reinstall the BJ cartridge correctly.
	The paper thickness lever is not set properly.	Set the lever at the specified position.
	The problem occurs when the user's BJ cartridge (causing the problem) is installed in a normally-operating printer.	Replace the BJ cartridge.
Corrugated printing	The carriage guide frame is deformed.	Replace the printer frame unit.
	Frictional wear between the carriage base and carriage shaft.	Replace the carriage unit.
The printout is either light or dark.	Check the printing mode.	Set the desired printing mode.
	The BJ cartridge is faulty.	Replace the BJ cartridge.

6. Faulty Interface

- <Symptom>**
- Nothing is printed.
 - An unspecified font is printed.
 - An unspecified color is printed.
- <Cause>**
- The printer driver setting is faulty.
 - The interface cable is faulty.
 - The printer's logic board is faulty.

<Measure>

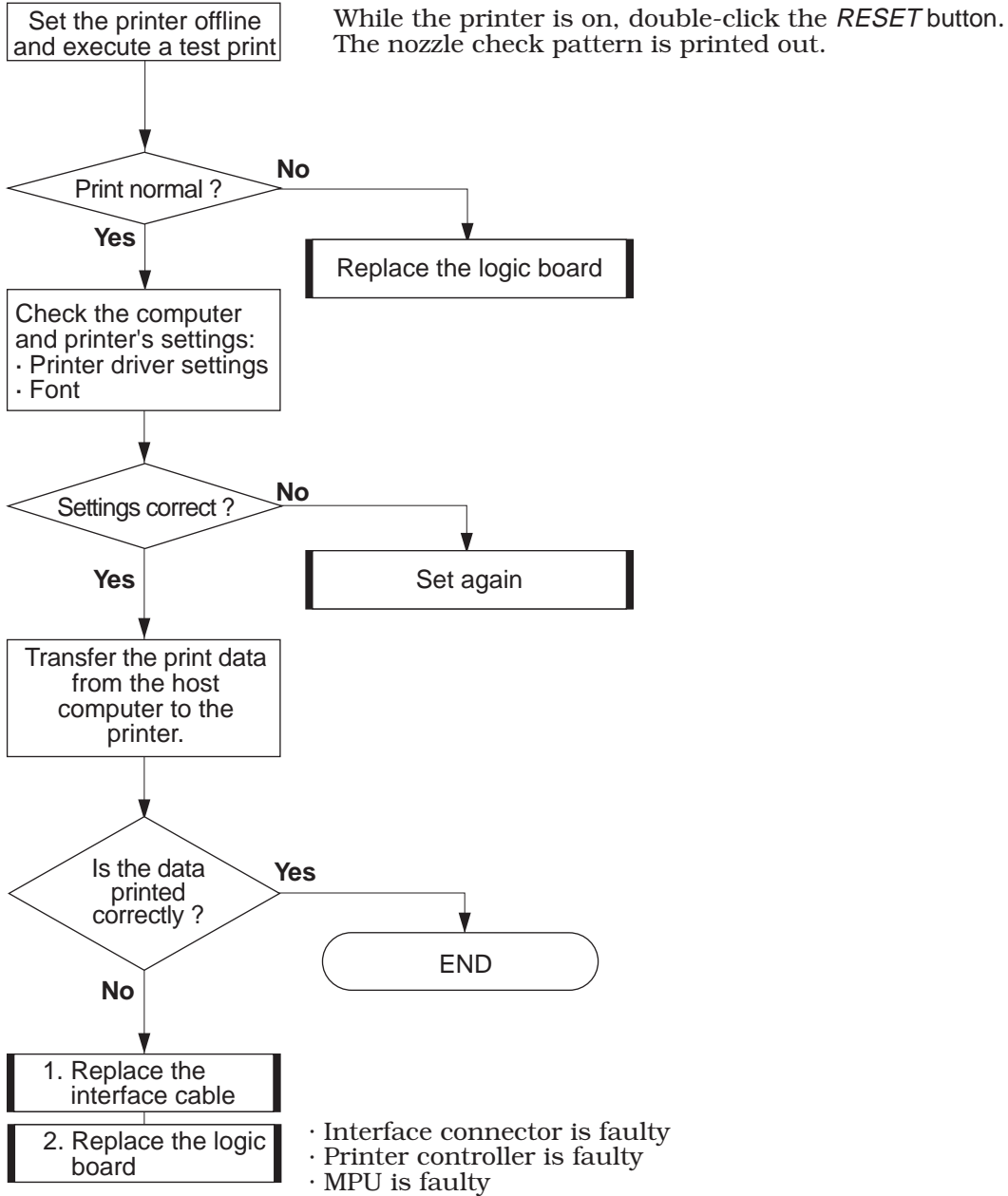

6. LOCATION & SIGNAL ASSIGNMENT

6.1 Logic Board

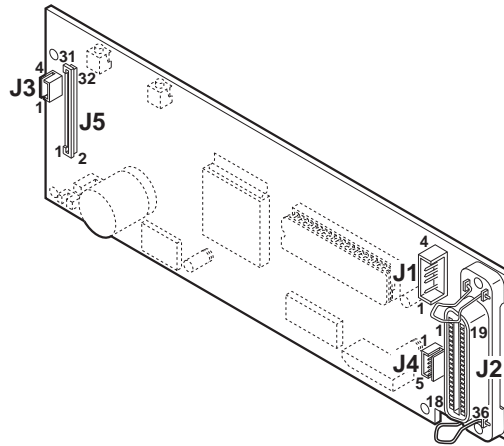

Figure 5-3 Logic Board

J5/CNH (Ribbon cable connector)

Pin No.	Signal name	IN/OUT	Description
1	VHG	...	GND for head drive voltage VH
2	VHG	...	GND for head drive voltage VH
3	HT0	IN	Driver signal for temperature control heater
4	HT1	IN	Driver signal for temperature control heater
5	HVH	OUT	Head driver voltage
6	HVH	OUT	Head driver voltage
7	W-HT	OUT	Drive signal for temperature control heater
8	INKS1	...	Not used
9	TOP	IN	Detection signal for rank resistance
10	DIODEA	OUT	Head temperature sensor (diode) anode
11	ID0	IN	Cartridge detection and recognition signal
12	ID1	IN	Cartridge detection and recognition signal
13	INKS2	IN/OUT	Cartridge detection and recognition signal
14	HVss	...	Head's logic drive voltage HVdd GND
15	HENB0(Y)	OUT	Heat enable
16	Even ENB	OUT	Even nozzle heat enable
17	HENB1(M)	OUT	Heat enable
18	HENB3(B)	OUT	Heat enable
19	Odd ENB	OUT	Odd nozzle heat enable
20	BENB1	OUT	Block enable generation signal
21	BENB2	OUT	Decoder output signal
22	BENB3	OUT	Decoder output signal
23	HVdd	OUT	IC drive voltage (+5 V)
24	HCLK	OUT	Print data transfer signal
25	HLATCH	OUT	Timing signal for print data to latch
26	HRES	OUT	Latch reset signal
27	HENB2(C)	OUT	Heat enable
28	HDATA	OUT	Printing data
29	DIODEK	IN	Head temperature sensor (diode) cathode
30	HPO	IN	Home position sense High/ Low(sense)
31	HPG	...	Ground
32	HPA	OUT	Photo LED drive

J1/CNPW (DC power connector)

Pin No.	Signal name	IN/OUT	Description
1	V _H	IN	24 VDC
2	V _{cc}	IN	5 VDC
3	GND	...	Ground
4	GND	...	Ground

J2/CNIF (Interface connector)

Pin No.	Signal name	IN/OUT	Description
1	STROBE	IN	See Part2 for details
2	DATA1	IN	
3	DATA2	IN	
4	DATA3	IN	
5	DATA4	IN	
6	DATA5	IN	
7	DATA6	IN	
8	DATA7	IN	
9	DATA8	IN	
10	ACKNLG	OUT	
11	BUSY	OUT	
12	P.E.	OUT	
13	SELECT	OUT	
14	AUTO FEED XT	IN	
15	N.C	...	
16	GND	...	
17	GND	...	
18	+5.0V	OUT	
19	STROBE-GND	...	
20	DATA1-GND	...	
21	DATA2-GND	...	
22	DATA3-GND	...	
23	DATA4-GND	...	
24	DATA5-GND	...	
25	DATA6-GND	...	
26	DATA7-GND	...	
27	DATA8-GND	...	
28	ACKNLG-GND	...	
29	BUSY-GND	...	
30	INT-GND	...	
31	INIT	IN	
32	ERROR	OUT	
33	GND	...	
34	N.C	...	
35	+5.0V	...	
36	SELECT IN	IN	

J3/CNCR (Carriage motor connector)

Pin No.	Signal name	IN/OUT	Description
1	CRA	OUT	Carriage motor phase A
2	CRĀ	OUT	Carriage motor phase Ā
3	CRB	OUT	Carriage motor phase B
4	CRB̄	OUT	Carriage motor phase B̄

J4/CNLF (Paper feed motor connector)

Pin No.	Signal name	IN/OUT	Description
1	LFB̄	OUT	Paper feed motor phase B̄
2	LFA	OUT	Paper feed motor phase A
3	VM	...	Common
4	LFA	OUT	Paper feed motor phase A
5	LFB	OUT	Paper feed motor phase B

6.2 Carriage Ribbon Cable

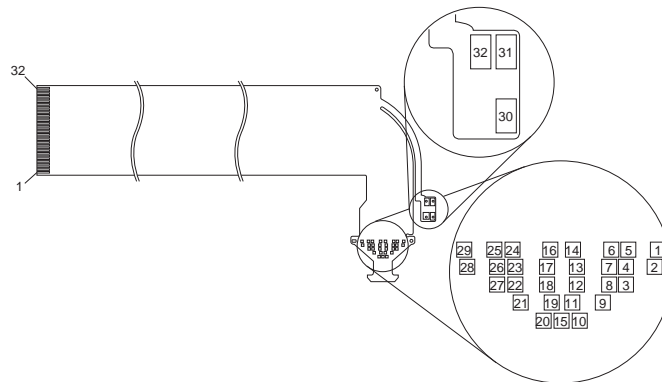

Figure 5-4 Carriage Ribbon Cable

Pin No.	Signal name	IN/OUT	Description
1	VHG	...	GND for head drive voltage VH
2	VHG	...	GND for head drive voltage VH
3	HT0	IN	Driver signal for temperature control heater
4	HT1	IN	Driver signal for temperature control heater
5	HVH	OUT	Head driver voltage
6	HVH	OUT	Head driver voltage
7	W-HT	OUT	Drive signal for temperature control heater
8	INKS1	...	Not used
9	TOP	IN	Detection signal for rank resistance
10	DIODEA	OUT	Head temperature sensor (diode) anode
11	ID0	IN	Cartridge detection and recognition signal
12	ID1	IN	Cartridge detection and recognition signal
13	INKS2	IN/OUT	Cartridge detection and recognition signal
14	HVss	...	Head's logic drive voltage HVdd GND
15	HENB0(Y)	OUT	Heat enable
16	Even ENB	OUT	Even nozzle heat enable
17	HENB1(M)	OUT	Heat enable
18	HENB3(B)	OUT	Heat enable
19	Odd ENB	OUT	Odd nozzle heat enable
20	BENB1	OUT	Block enable generation signal
21	BENB2	OUT	Decoder output signal
22	BENB3	OUT	Decoder output signal
23	HVdd	OUT	IC drive voltage (+5 V)
24	HCLK	OUT	Print data transfer signal
25	HLATCH	OUT	Timing signal for print data to latch
26	HRES	OUT	Latch reset signal
27	HENB2(C)	OUT	Decoder output signal
28	HDATA	OUT	Printing data
29	DIODEK	IN	Head temperature sensor (diode) cathode
30	HPO	IN	Home position sense High/ Low(sense)
31	HPG	...	Ground
32	HPA	OUT	Photo LED drive

Pins 1 to 29 on the contact pad of the BJ cartridge and scanner cartridge are arranged to correspond respectively to pins 1 to 29 on the carriage ribbon cable. Connector pins 10 and 29 are used to detect whether or not a cartridge is installed. Connector pins 11, 12 and 13 (ID0, ID1 and INKS2) are used to recognize the cartridge type as shown in the table below.

	ID0	ID1	INKS2
Black BJ cartridge installed	Low	Low	High
Color BJ cartridge (Multi-Drop) installed	High	Low	Low
Photo BJ cartridge (Multi-Drop) installed	High	High	Low
Scanner cartridge installed	High	Low	Low

High: Signal detected

Low: No signal detection (by printer)

6.3 BJ Cartridge & Scanner Cartridge

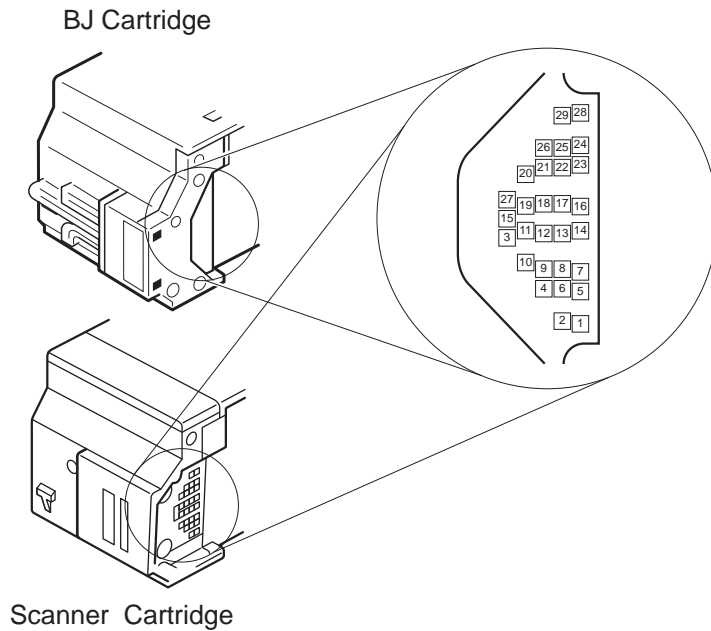

Figure 5-5 Contact Pad

BJ cartridge

Pin No.	Signal name	IN/OUT	Description
1, 2	VHG	GND	GND for head driver voltage VH
3	HT0	OUT	Temperature control heater drive signal
4	HT1	OUT	Temperature control heater drive signal
5, 6	HVH	IN	Head drive voltage (ink ejection heater, temperature control heater, sub heater driver)
7	W-HT	IN	Sub heater drive signal
8	INKS1	...	Not used
9	TOP	OUT	Rank resistance detection signal
10	DIODEA	IN	Head temperature sensor(diode) anode
11	ID0	OUT	Cartridge detection and recognition signal
12	ID1	OUT	Cartridge detection and recognition signal
13	INKS2	IN/OUT	Cartridge detection and recognition signal
14	HVss	GND	Head's logic drive voltage HVdd GND
15	HENB0	IN	Heat enable
17	HENB1	IN	· Black BJ cartridge: Uses only pin No. 15 and 17
27	HENB2	IN	· Color/Photo BJ cartridge: Uses all pins
18	HENB3	IN	(The respective color is show in parentheses.)
16	Even ENB	IN	Even nozzle heat enable
19	Odd ENB	IN	Odd nozzle heat enable
20	BENB1	IN	Block enable decoder's output generation signal
21	BENB2	IN	Block enable decoder's output generation signal
22	BENB3	IN	Block enable decoder's output generation signal
23	HVdd	IN	IC driver voltage (+5 V)
24	HCLK	IN	Print data transfer signal
25	HLATCH	IN	Shift resistor print data latch timing signal
26	HRES	IN	Latch reset signal
28	HDATA	IN	Printing data
29	DIODEK	OUT	Head temperature sensor (diode) cathode

Scanner cartridge

No.	Signal	Type	Description	(Ref. BJ Cartridge)
1, 2	LAMP G	...	GND for LED	VHG
5, 6	V LAMP	...	LED drive voltage (+24Vdc)	HVH
9	TOP. S	OUT	Scanner detection GND	TOP
10	DIA. S	...	Scanner detection OPEN	DIODEA
11	ID0	IN	Not used	ID0
12	ID1	IN	Not used	ID1
14	Vss	GND	GND	HVss
19	COM 0 (REN)	IN	Register enable	Odd ENB
20	COM 1 (RWR)	IN	Register write clock signal	BENB1
21	COM 2 (RDT)	IN	Register data signal	BENB2
22	COM 3 (N.C)	...	Not used	BENB3
23	Vdd	...	IC driver voltage (+5 Vdc)	HVdd
24	S CLOCK	OUT	Scan data transfer signal	HCLK
25	S SYNE	IN	Line start signal	HLATCH
26	S RES	OUT	System reset signal	HRES
28	S DATA	OUT	Scan data	HDATA
29	C. CHK	OUT	HScanner detection OPEN	DIODEK

7. CIRCUIT DIAGRAMS

7.1 Parts Layout 7.1.1 Logic board

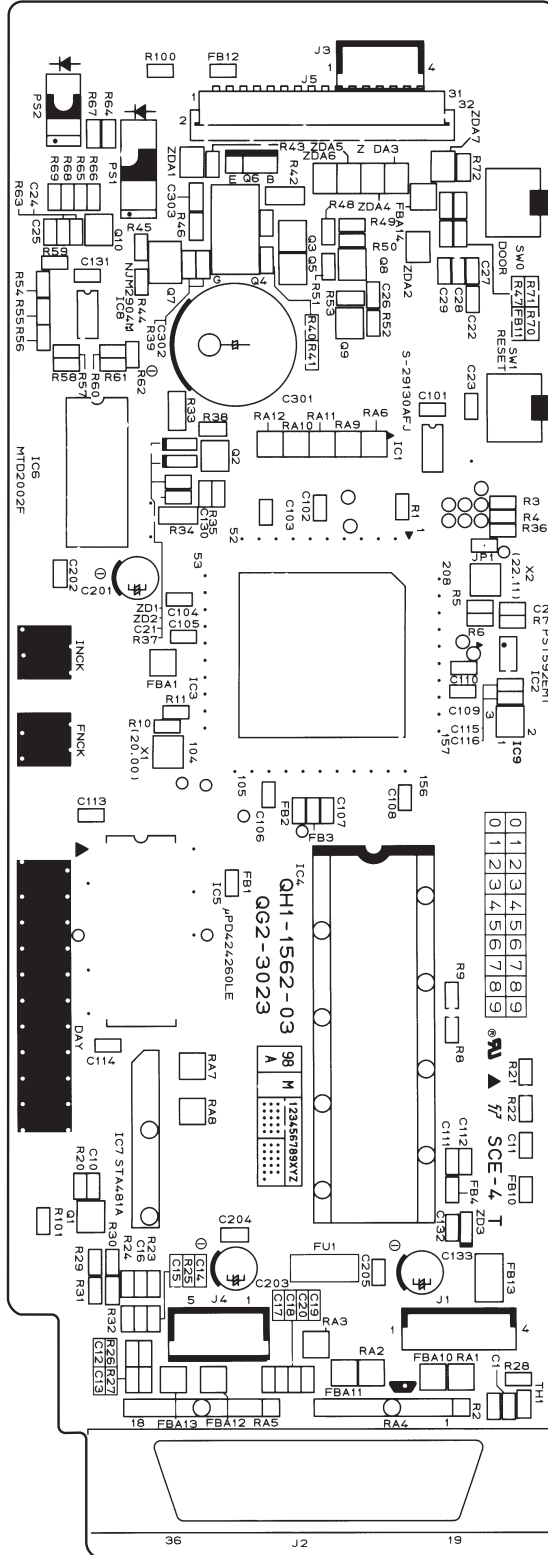
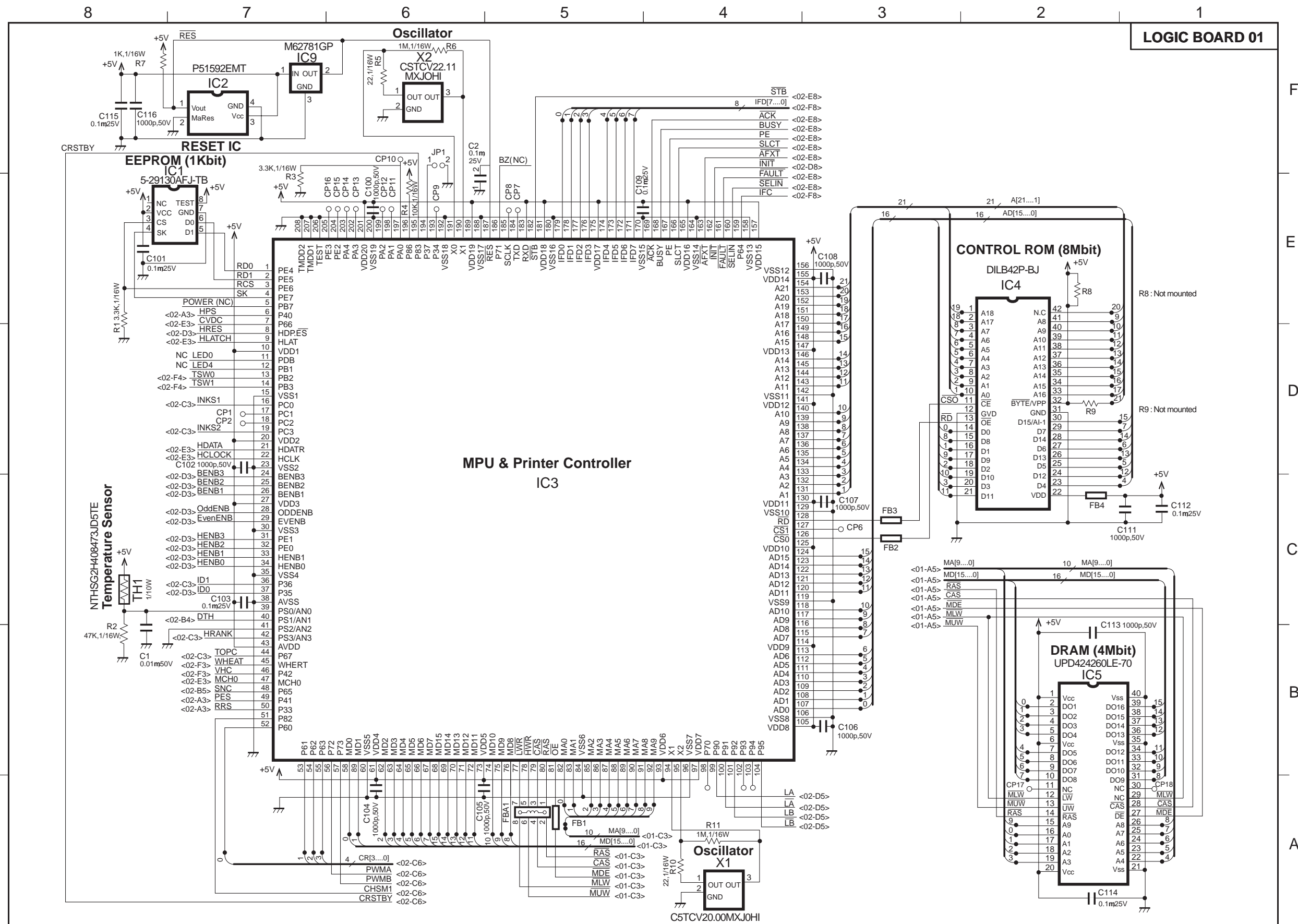
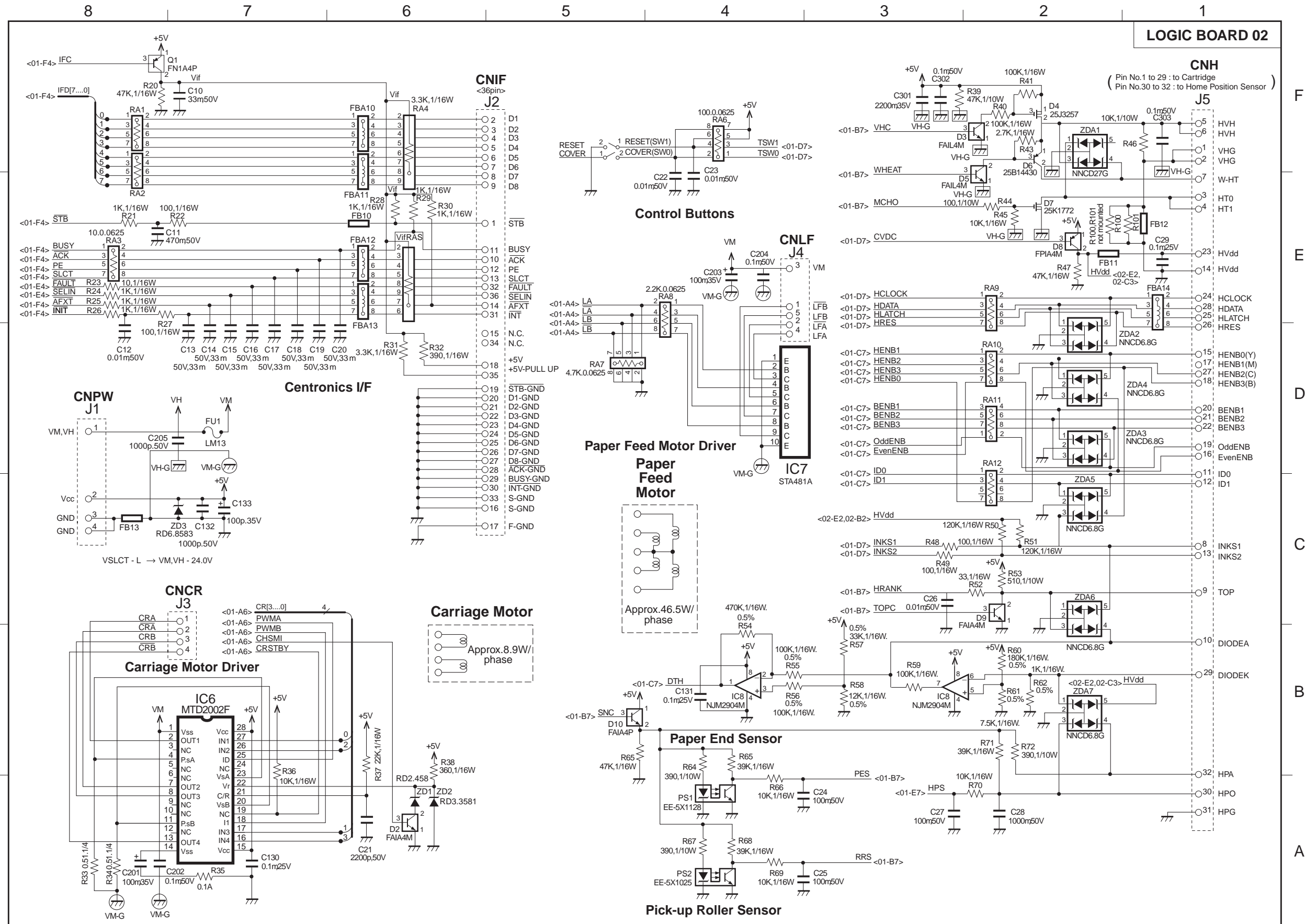

Figure 5-6 Logic Board (Top View)

7.2 Circuit Diagrams







The printing paper contains
70% waste paper.

Canon